

Visit [www.carrier.com](http://www.carrier.com)

## Installation, Start-Up, and Operating Instructions 50GS Sizes 018-060, 50GX Sizes 024-060

**NOTE:** Read the entire instruction manual before starting the installation.

This symbol → indicates a change since the last issue.

### TABLE OF CONTENTS

<p>SAFETY CONSIDERATIONS .....1</p> <p>Introduction .....2</p> <p>RECEIVING AND INSTALLATION .....2</p> <p style="padding-left: 20px;">Check Equipment.....2</p> <p style="padding-left: 40px;">IDENTIFY UNIT.....2</p> <p style="padding-left: 40px;">INSPECT SHIPMENT.....2</p> <p style="padding-left: 20px;">Provide Unit Support.....2</p> <p style="padding-left: 40px;">ROOF CURB.....2</p> <p style="padding-left: 40px;">SLAB MOUNT.....2</p> <p style="padding-left: 40px;">GROUND MOUNT.....2</p> <p style="padding-left: 20px;">Provide Clearances.....2</p> <p style="padding-left: 20px;">Field Fabricate Ductwork.....2</p> <p style="padding-left: 20px;">Rig and Place Unit.....2</p> <p style="padding-left: 40px;">INSPECTION.....3</p> <p style="padding-left: 40px;">INSTALLATION.....3</p> <p style="padding-left: 20px;">Connect Condensate Drain.....7</p> <p style="padding-left: 20px;">Install Duct Connections.....7</p> <p style="padding-left: 40px;">CONFIGURING UNITS FOR DOWNFLOW (VERTICAL) DISCHARGE.....8</p> <p style="padding-left: 20px;">Install Electrical Connection.....9</p> <p style="padding-left: 40px;">HIGH-VOLTAGE CONNECTIONS.....10</p> <p style="padding-left: 40px;">SPECIAL PROCEDURES FOR 208-V OPERATION...10</p> <p style="padding-left: 40px;">CONTROL VOLTAGE CONNECTIONS.....10</p> <p style="padding-left: 40px;">STANDARD CONNECTION.....10</p> <p style="padding-left: 40px;">TRANSFORMER PROTECTION.....13</p> <p>PRE-START-UP .....13</p> <p>START-UP .....14</p> <p style="padding-left: 20px;">CHECK FOR REFRIGERANT LEAKS.....14</p> <p style="padding-left: 20px;">START UP COOLING SECTION AND MAKE ADJUSTMENTS.....14</p> <p style="padding-left: 20px;">CHECKING COOLING CONTROL OPERATION.....14</p> <p style="padding-left: 20px;">CHECKING AND ADJUSTING REFRIGERANT CHARGE.....14</p> <p style="padding-left: 20px;">INDOOR AIRFLOW AND AIRFLOW ADJUSTMENTS.....18</p> <p style="padding-left: 40px;">For 208/230V.....18</p> <p style="padding-left: 40px;">FOR 460-V GE MOTORS.....18</p> <p style="padding-left: 20px;">COOLING SEQUENCE OF OPERATION.....18</p> <p>MAINTENANCE.....18</p> <p style="padding-left: 20px;">AIR FILTER.....22</p> <p style="padding-left: 20px;">EVAPORATOR BLOWER AND MOTOR.....22</p> <p style="padding-left: 20px;">CONDENSER COIL, EVAPORATOR COIL, AND CONDENSATE DRAIN PAN.....24</p> <p style="padding-left: 20px;">CONDENSER FAN.....24</p> <p style="padding-left: 20px;">ELECTRICAL CONTROLS AND WIRING.....24</p> <p style="padding-left: 20px;">REFRIGERANT CIRCUIT.....24</p> <p style="padding-left: 20px;">EVAPORATOR AIRFLOW.....25</p>	<p>METERING DEVICE — ACUTROL DEVICE .....25</p> <p>LIQUID LINE STRAINER .....25</p> <p>Troubleshooting.....25</p> <p>Start-Up Checklist.....25</p> <p>NOTE TO INSTALLER — Before the installation, READ THESE INSTRUCTIONS CAREFULLY AND COMPLETELY. Also, make sure the User's Manual and Replacement Guide are left with the unit after installation.</p>
---	---

### SAFETY CONSIDERATIONS

Installation and servicing of air-conditioning equipment can be hazardous due to system pressure and electrical components. Only trained and qualified personnel should install, repair, or service air-conditioning equipment.

Untrained personnel can perform basic maintenance functions of cleaning coils and filters. All other operations should be performed by trained service personnel. When working on air-conditioning equipment, observe precautions in the literature, tags, and labels attached to the unit, and other safety precautions that may apply.

Follow all safety codes. Wear safety glasses and work gloves. Use quenching cloth for unbrazing operations. Have fire extinguisher available for all brazing operations. Consult a qualified installer or service agency for information or assistance. The qualified installer or agency must use only factory-authorized kits or accessories when modifying this product.

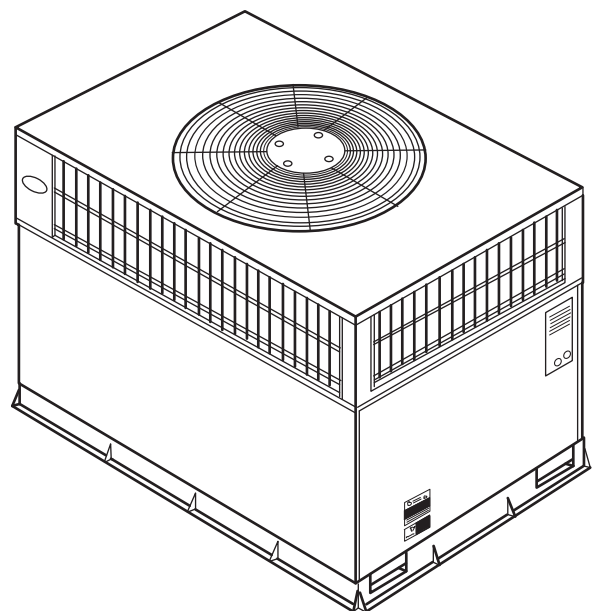

C99001

**Fig. 1—Unit 50GS and 50GX**

Manufacturer reserves the right to discontinue, or change at any time, specifications or designs without notice and without incurring obligations.

## ⚠ WARNING

Before performing service or maintenance operations on system, turn off power to unit. Turn off accessory heater power switch, if applicable. Electrical shock can cause personal injury.

Recognize safety information. This is the safety-alert symbol ⚠. When you see this symbol in instructions or manuals, be alert to the potential for personal injury.

Understand the signal words DANGER, WARNING, CAUTION, and NOTE. These words are used with the safety-alert symbol. DANGER identifies the most serious hazards which **will** result in severe personal injury or death. WARNING signifies a hazard which **could** result in personal injury or death. CAUTION is used to identify unsafe practices which **would** result in minor personal injury or product and property damage. NOTE is used to highlight suggestions which **will** result in enhanced installation, reliability, or operation.

These instructions cover minimum requirements and conform to existing national standards and safety codes. In some instances, these instructions exceed certain local codes and ordinances, especially those that may not have kept up with changing residential construction practices. We require these instructions as a minimum for a safe installation.

## INTRODUCTION

The 50GS and 50GX units (see Fig. 1) are fully self-contained, and designed for outdoor installation. See Figs. 2 and 3 for unit dimensions. All unit sizes have discharge openings for both horizontal and downflow configurations, and are factory shipped with all downflow duct openings covered. Units may be installed either on a rooftop, ground-level cement slab, or directly on the ground if local codes permit. (See Fig. 4A for roof curb dimensions.)

## RECEIVING AND INSTALLATION

### Step 1—Check Equipment

#### IDENTIFY UNIT

The unit model number and serial number are stamped on the unit identification plate. Check this information against shipping papers.

#### INSPECT SHIPMENT

Inspect for shipping damage while unit is still on shipping pallet. If unit appears to be damaged or is torn loose from its anchorage, have it examined by transportation inspectors before removal. Forward claim papers directly to transportation company. Manufacturer is not responsible for any damage incurred in transit. Check all items against shipping list. Immediately notify the nearest Carrier Air Conditioning office if any item is missing. To prevent loss or damage, leave all parts in original packages until installation.

### Step 2—Provide Unit Support

#### ROOF CURB

Install accessory roof curb in accordance with instructions shipped with curb (See Fig. 4A). Install insulation, cant strips, roofing, and flashing. Ductwork must be attached to curb.

**IMPORTANT:** The gasketing of the unit to the roof curb is critical for a watertight seal. Install gasketing material supplied with the roof curb. Improperly applied gasketing also can result in air leaks and poor unit performance.

Curb should be level to within 1/4 in. (See Fig. 5A). This is necessary for unit drain to function properly. Refer to accessory roof curb installation instructions for additional information as required.

## SLAB MOUNT

Place the unit on a solid, level concrete pad that is a minimum of 4 in. thick with 2 in. above grade (See Fig. 5B). The slab should extend approximately 2 in. beyond the casing on all 4 sides of the unit. Do not secure the unit to the slab *except* when required by local codes.

## GROUND MOUNT

The unit may be installed either on a slab or placed directly on the ground if local codes permit. Place the unit on level ground prepared with gravel for condensate discharge.

### Step 3—Provide Clearances

The required minimum service clearances are shown in Fig. 2 & 3. Adequate ventilation and outdoor air must be provided. The outdoor fan draws air through the outdoor coil and discharges it through the top fan grille. Be sure that the fan discharge does not recirculate to the outdoor coil. Do not locate the unit in either a corner or under an overhead obstruction. The minimum clearance under a partial overhang (such as a normal house overhang) is 36 in. above the unit top. The maximum horizontal extension of a partial overhang must not exceed 48 in. For extended overhangs, provide a minimum clearance of 48 in.

**IMPORTANT:** Do not restrict outdoor airflow. An air restriction at either the outdoor-air inlet or the fan discharge may be detrimental to compressor life.

Do not place the unit where water, ice, or snow from an overhang or roof will damage or flood the unit. Do not install the unit on carpeting or other combustible materials. Slab-mounted units should be at least 4 in. above the highest expected water and runoff levels. Do not use unit if it has been under water.

### Step 4—Field Fabricate Ductwork

Secure all ducts to roof curb and building structure on vertical discharge units. *Do not connect ductwork to unit.* For horizontal applications, unit is provided with flanges on the horizontal openings. All ductwork should be secured to the flanges. Insulate and weatherproof all external ductwork, joints, and roof openings with counter flashing and mastic in accordance with applicable codes.

Ducts passing through an unconditioned space must be insulated and covered with a vapor barrier. If a plenum return is used on a vertical unit, the return should be ducted through the roof deck to comply with applicable fire codes. A minimum clearance is not required around ductwork. Cabinet return-air static shall not exceed -.25 in. wg.

### Step 5—Rig and Place Unit

Rigging and handling of this equipment can be hazardous for many reasons due to the installation location (roofs, elevated structures, etc.)

Only trained, qualified crane operators and ground support staff should handle and install this equipment.

When working with this equipment, observe precautions in the literature, on tags, stickers, and labels attached to the equipment, and any other safety precautions that might apply.

Follow all applicable safety codes. Wear safety shoes and work gloves.

## ⚠ WARNING

Never stand beneath rigged units or lift over people.

## ⚠ WARNING

Never exceed 200 lbs. per bracket lifting force.

DIMENSIONS IN [ ] ARE IN INCHES

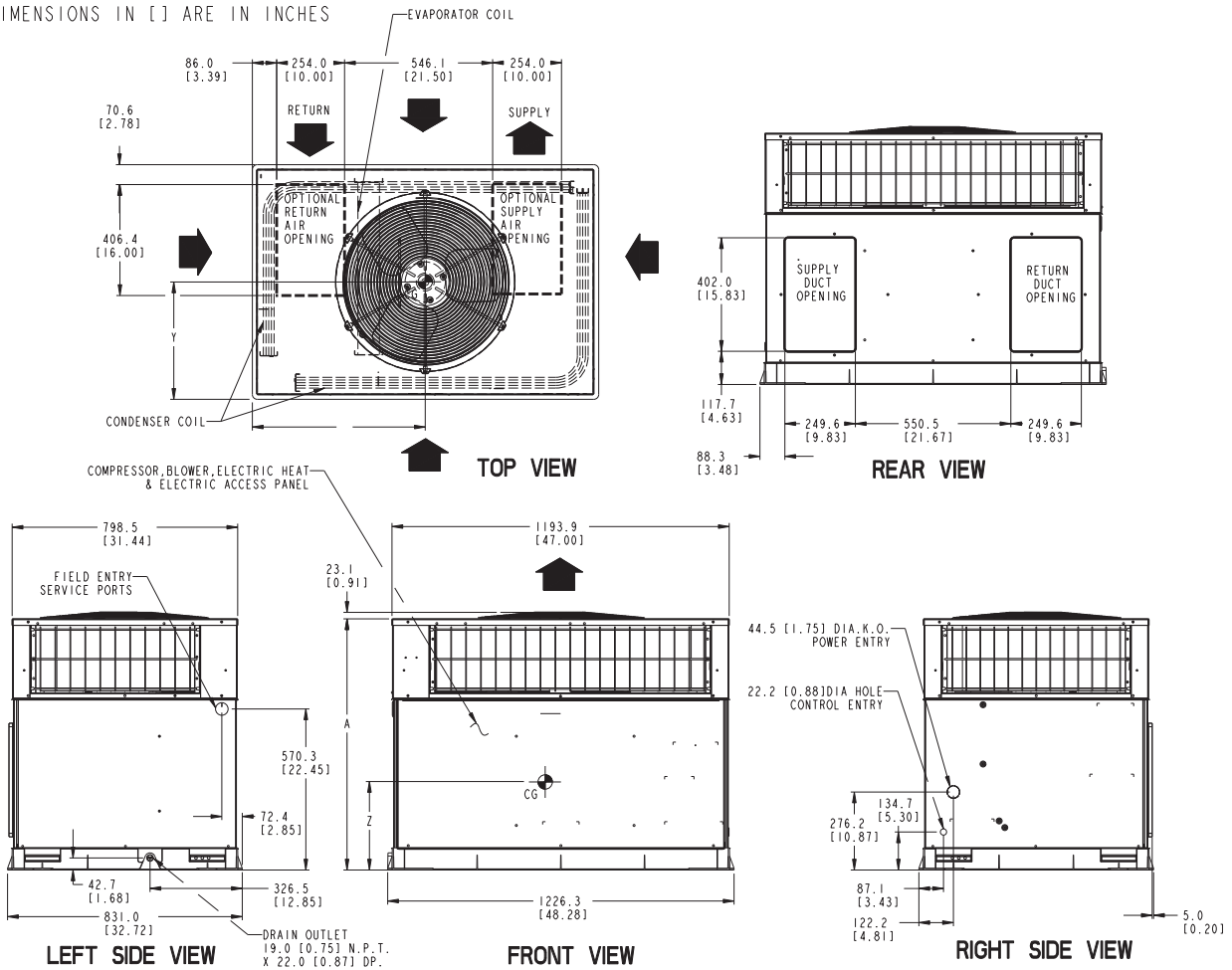

**REQUIRED CLEARANCE TO COMBUSTIBLE MATL.**

	INCHES [mm]
TOP OF UNIT	14.00 [355.6]
DUCT SIDE OF UNIT	2.00 [50.8]
SIDE OPPOSITE DUCTS	14.00 [355.6]
BOTTOM OF UNIT	0.50 [12.7]
ELECTRIC HEAT PANEL	36.00 [914.4]

**NEC. REQUIRED CLEARANCES.**

	INCHES [mm]
BETWEEN UNITS, POWER ENTRY SIDE	42.00 [1066.8]
UNIT AND UNGROUNDED SURFACES, POWER ENTRY SIDE	36.00 [914.0]
UNIT AND BLOCK OR CONCRETE WALLS AND OTHER GROUNDED SURFACES, POWER ENTRY SIDE	42.00 [1066.8]

**REQUIRED CLEARANCE FOR OPERATION AND SERVICING**

	INCHES [mm]
EVAP. COIL ACCESS SIDE	36.00 [914.0]
POWER ENTRY SIDE	42.00 [1066.8]
(EXCEPT FOR NEC REQUIREMENTS)	
UNIT TOP	48.00 [1219.2]
SIDE OPPOSITE DUCTS	36.00 [914.0]
DUCT PANEL	12.00 [304.8] *

\*MINIMUM DISTANCES: IF UNIT IS PLACED LESS THAN 304.8 [1200] FROM WALL SYSTEM, THEN SYSTEM PERFORMANCE MAYBE COMPROMISE.

C99007

UNIT	ELECTRICAL CHARACTERISTICS	UNIT WEIGHT		UNIT HEIGHT IN. (MM) "A"	CENTER OF GRAVITY IN. (MM)		
		lb.	kg		X	Y	Z
50GS018	208/230-1-60	254	115.2	35.02 (889.5)	20.0 (508.0)	13.0 (330.2)	15.0 (381.0)
50GS024	208/230-1-60	260	117.9	35.02 (889.5)	19.0 (482.6)	13.0 (330.2)	15.0 (381.0)
50GS030	208/230-1-60, 208/230-3-60	258	117.0	35.02 (889.5)	19.0 (482.6)	14.0 (355.6)	15.0 (381.0)
50GS036	208/230-1-60, 208/230-3-60, 460-3-60	268	121.6	37.02 (940.3)	20.0 (508.0)	14.0 (355.6)	13.0 (330.2)
50GS042	208/230-1-60, 208/230-3-60, 460-3-60	294	133.3	35.02 (889.5)	19.0 (482.6)	14.0 (355.6)	13.0 (330.2)
50GX024	208/230-1-60	270	122.5	37.02 (940.3)	18.5 (469.9)	14.5 (368.3)	16.0 (406.4)
50GX030	208/230-1-60, 208/230-3-60	291	132.0	39.02 (991.1)	19.5 (495.3)	15.5 (393.7)	17.6 (447.0)
50GX036	208/230-1-60, 208/230-3-60, 460-3-60	299	135.6	35.02 (889.5)	19.5 (495.3)	15.25 (387.4)	16.5 (419.1)

**Fig. 2— 50GS018-042 and 50GX024-036 Unit Dimensions**

**⚠ WARNING**

Accessory lifting kit is only to be used with Small Packaged units which have a composite base pan with molded rigging holds.

**INSPECTION**

Prior to initial use, and at monthly intervals, all rigging brackets and straps should be visually inspected for any damage, evidence

of wear, structural deformation, or cracks. Particular attention should be paid to excessive wear at hoist hooking points and load support areas. Brackets or straps showing any kind of wear in these areas must not be used and should be discarded.

**INSTALLATION**

1. Position the lifting bracket assembly around the base of the unit. Leave the top shipping skid on the unit to act as a spreader bar. Be sure the strap does not twist.

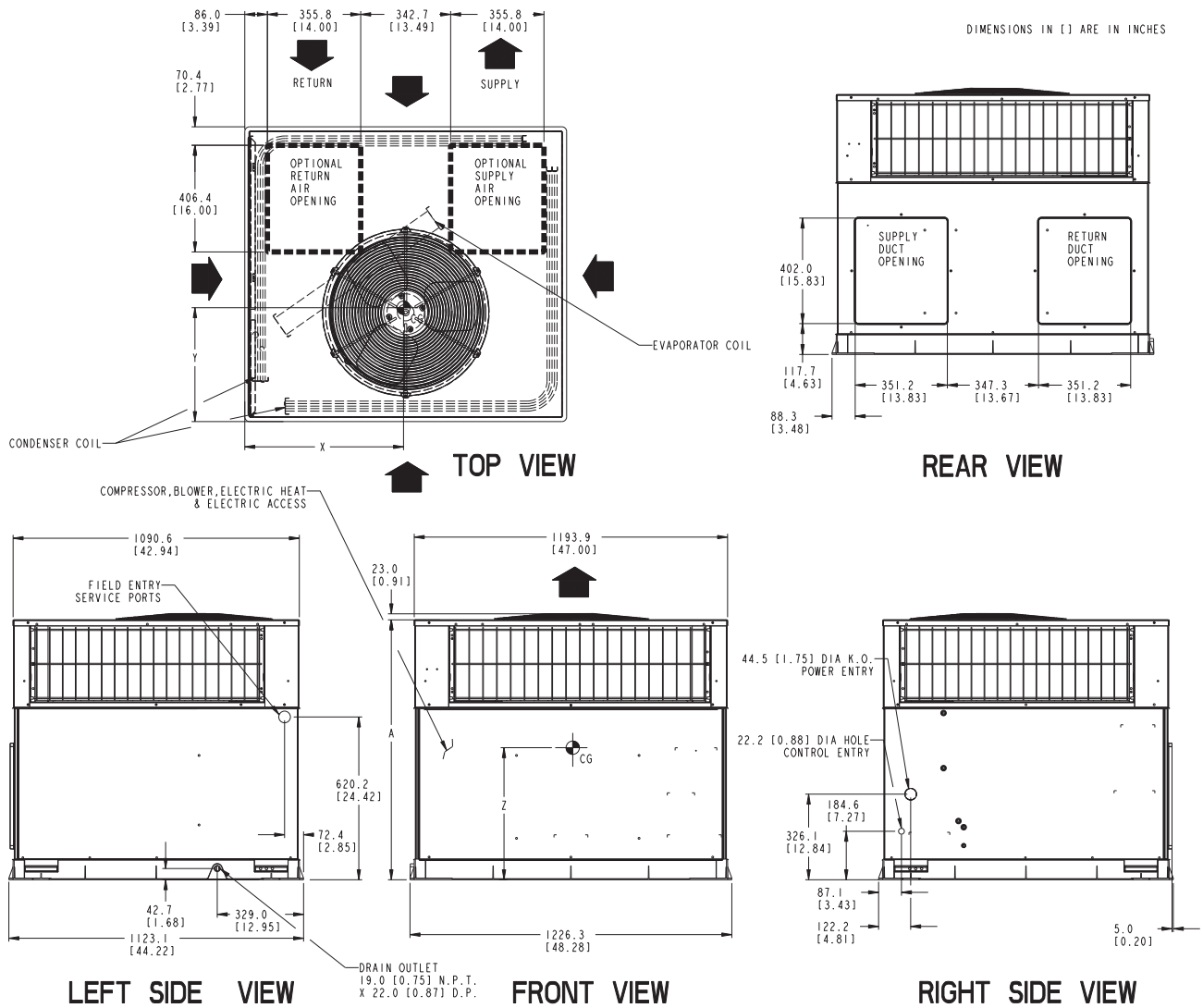

**REQUIRED CLEARANCE TO COMBUSTIBLE MATL.**

	INCHES [mm]
TOP OF UNIT.....	14.00 [355.6]
DUCT SIDE OF UNIT.....	2.00 [50.8]
SIDE OPPOSITE DUCTS.....	14.00 [355.6]
BOTTOM OF UNIT.....	0.50 [12.7]
ELECTRIC HEAT PANEL.....	36.00 [914.4]

**NEC. REQUIRED CLEARANCES.**

	INCHES [mm]
BETWEEN UNITS, POWER ENTRY SIDE.....	42.00 [1066.8]
UNIT AND UNGROUNDED SURFACES, POWER ENTRY SIDE.....	36.00 [914.0]
UNIT AND BLOCK OR CONCRETE WALLS AND OTHER GROUNDED SURFACES, POWER ENTRY SIDE.....	42.00 [1066.8]

**REQUIRED CLEARANCE FOR OPERATION AND SERVICING**

	INCHES [mm]
EVAP. COIL ACCESS SIDE.....	36.00 [914.0]
POWER ENTRY SIDE.....	36.00 [914.0]
(EXCEPT FOR NEC REQUIREMENTS)	
UNIT TOP.....	48.00 [1219.2]
SIDE OPPOSITE DUCTS.....	36.00 [914.0]
DUCT PANEL.....	12.00 [304.8] *

\*MINIMUM DISTANCES: IF UNIT IS PLACED LESS THAN 304.8 [1200] FROM WALL SYSTEM, THEN SYSTEM PERFORMANCE MAYBE COMPROMISE.

C99006

UNIT	ELECTRICAL CHARACTERISTICS	UNIT WEIGHT		UNIT HEIGHT IN. (MM) "A"	CENTER OF GRAVITY IN. (MM)		
		lb.	kg		X	Y	Z
50GS048	208/230-1-60, 208/230-3-60, 460-3-60	324	145	38.98 (990.2)	20.0 (508.0)	17.0 (432.0)	17.0 (432.0)
50GS060	208/230-1-60, 208/230-3-60, 460-3-60	389	176	38.98 (990.2)	19.0 (482.6)	16.0 (406.0)	17.0 (432.0)
50GX042	208/230-1-60, 208/230-3-60, 460-3-60	321	146	38.98 (990.2)	20.5 (520.7)	16.75 (425.5)	16.6 (421.6)
50GX048	208/230-1-60, 208/230-3-60, 460-3-60	326	148	38.98 (990.2)	19.5 (495.3)	17.6 (447.6)	18.0 (457.2)
50GX060	208/230-1-60, 208/230-3-60, 460-3-60	399	181	42.98 (1091.1)	20.5 (520.7)	16.2 (412.8)	17.6 (447.0)

**Fig. 3— 50GS048–060 and 50GX042–060 Unit Dimensions**

- Place each of the four (4) metal lifting brackets into the rigging holds in the composite pan.
- Tighten the ratchet strap unit tight. Lifting brackets should be secure in the rigging holds.
- Attach the clevis or hook of sufficient strength to hole in the lifting bracket (See Fig. 6).
- Attach safety straps directly to the field supplied rigging straps or clevis clip. Do not attach the safety straps to the lifting brackets.
- Use the top of the unit as a spreader bar to prevent the rigging straps from damaging the unit. If the wood top is not available, use a spreader bar of sufficient length to not damage the unit.

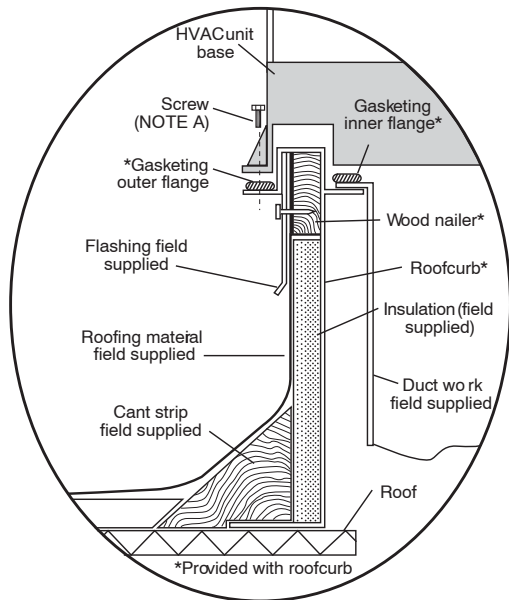

**Roof Curb for Small Cabinet**

Note A: When unit mounting screw is used, retainer bracket must also be used.

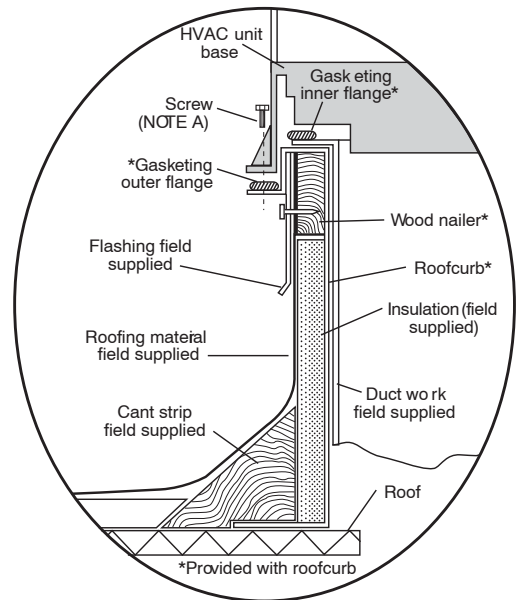

**Roof Curb for Large Cabinet**

Note A: When unit mounting screw is used, retainer bracket must also be used.

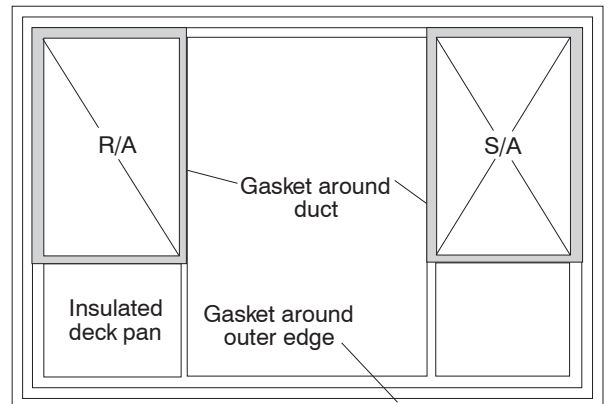
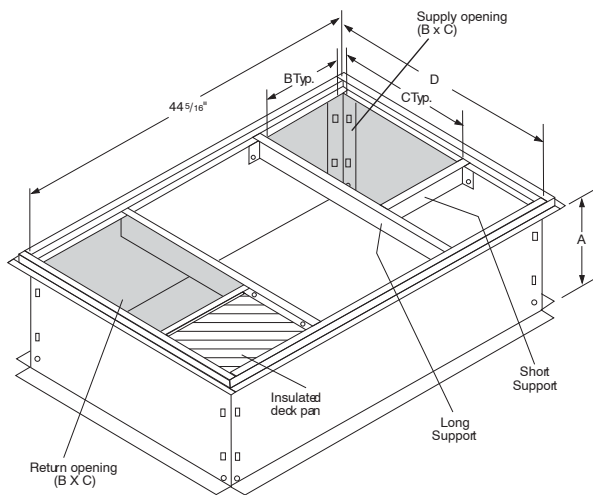

C00076

UNIT SIZE		ODS CATALOG NUMBER	A IN. (MM)	B IN. (MM)	C IN. (MM)	D IN. (MM)
<b>50GS018-042</b>	50GX024-036	CPRFCURB006A00	8 (203)	11 (279)	16-1/2 (419)	28-3/4 (730)
		CPRFCURB007A00	14 (356)	11 (279)	16-1/2 (419)	28-3/4 (730)
<b>50GS048-060</b>	50GX042-060	CPRFCURB008A00	8 (203)	16-3/16 (411)	17-3/8 (441)	40-1/4 (1022)
		CPRFCURB009A00	14 (356)	16-3/16 (411)	17-3/8 (441)	40-1/4 (1022)

- NOTES:
1. Dimensions in ( ) are in millimeters.
  2. Roof curb is made of 16-gage steel.
  3. Table lists only the dimensions per part number that have changed
  4. Insulated panels: 1-in. thick fiberglass 1 lb. density.

**Fig. 4A— Roof Curb Dimensions**



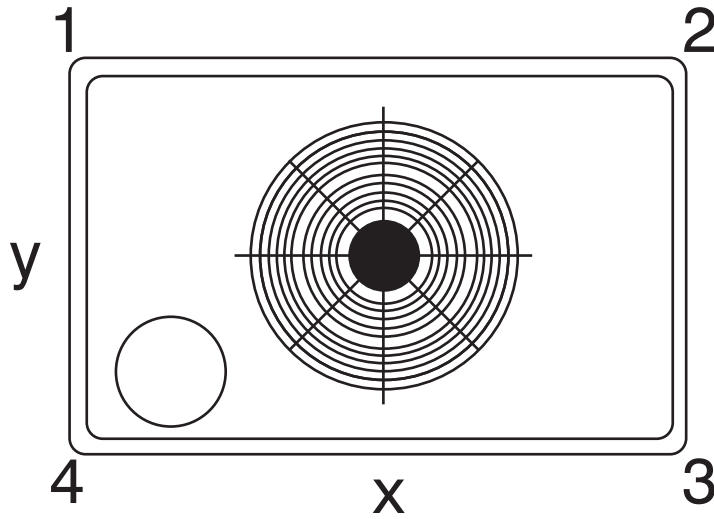

C00071

CORNER #	50GS							50GX					
	018	024	030	036	042	048	060	024	030	036	042	048	060
1	58	60	59	62	76	69	84	76	84	85	71	78	85
2	47	50	48	50	50	45	54	49	60	60	55	56	66
3	55	56	56	58	71	88	106	57	61	64	85	80	108
4	94	94	95	98	97	122	145	88	86	90	110	112	140
<b>TOTAL WEIGHT</b>	254	260	258	268	294	324	389	270	291	299	321	326	399

Fig. 4B—50GS and 50GX Unit Corner Weights

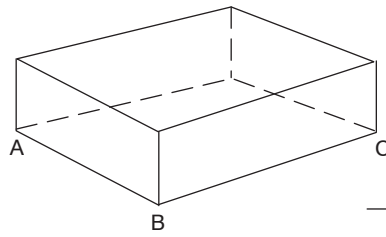

MAXIMUM ALLOWABLE DIFFERENCE (in.)

A-B	B-C	A-C
1/4	1/4	1/4

C99065

Fig. 5A—Unit Leveling Tolerances

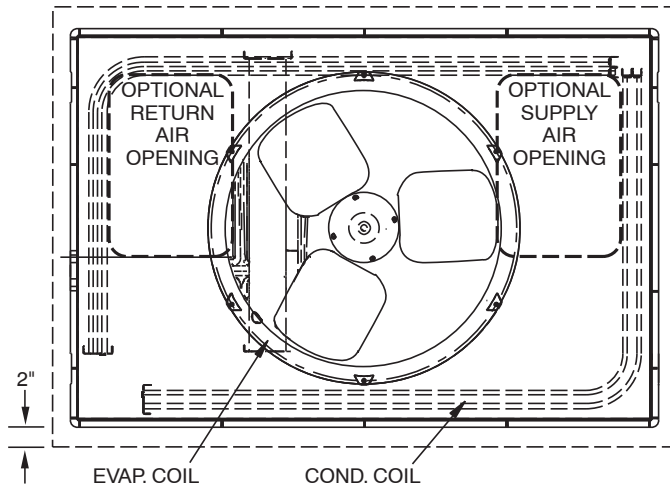

C99096

Fig. 5B—Slab Mounting Detail



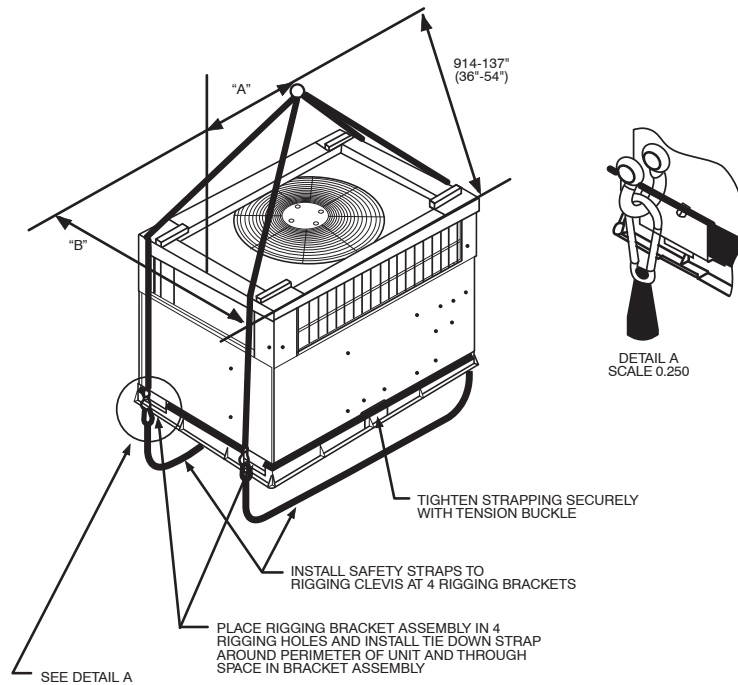

C99066

SIZE	MAXIMUM WEIGHT		A		B	
	lb.	kg	in.	mm.	in.	mm.
<b>UNIT 50GS</b>						
018	276	125.2	20	508.0	13	330.2
024	282	127.9	19	482.6	13	330.2
030	280	127.0	19	482.6	14	355.6
036	290	131.5	20	508.0	14	355.6
042	316	143.3	19	482.6	14	355.6
048	346	156.9	20	508.0	17	431.8
060	411	186.4	19	482.6	16	406.4
<b>UNIT 50GX</b>						
024	292	132.5	18.5	469.9	14.50	368.3
030	313	142.5	19.5	495.3	15.50	393.7
036	321	145.6	19.5	495.3	15.25	387.4
042	343	155.6	20.5	520.7	16.75	425.5
048	348	157.9	19.5	495.3	17.62	447.6
060	421	191.0	20.5	520.7	16.25	412.8

**Fig. 6—Suggested Rigging**

**⚠ WARNING**

Lifting point should be directly over the center of gravity for the unit.

**Step 6—Connect Condensate Drain**

**NOTE:** When installing condensate drain connection be sure to comply with local codes and restrictions.

Models 50GS and 50GX dispose of condensate water through a 3/4 in. NPT fitting which exits through the base on the evaporator coil access side. See Fig. 2 & 3 for location.

Condensate water can be drained directly onto the roof in rooftop installations (where permitted) or onto a gravel apron in ground-level installations. Install a field-supplied condensate trap at end of condensate connection to ensure proper drainage. Make sure that the outlet of the trap is at least 1 in. lower than the drainpan condensate connection to prevent the pan from overflowing (See Fig. 7). When using a gravel apron, make sure it slopes away from the unit.

Connect a drain tube using a minimum of 3/4 -in. PVC or 3/4 -in. copper pipe (all field-supplied) at the outlet end of the 2-in. trap.

Do not undersize the tube. Pitch the drain tube downward at a slope of at least 1-in. for every 10 ft. of horizontal run. Be sure to check the drain tube for leaks. Prime trap at the beginning of the cooling season start-up.

**Step 7—Install Duct Connections**

The unit has duct flanges on the supply- and return-air openings on the side and bottom of the unit. For downshot applications the ductwork can be connected to the roof curb. See Fig. 2 & 3 for connection sizes and locations.

**IMPORTANT:** Use flexible connectors between ductwork and unit to prevent transmission of vibration. Use suitable gaskets to ensure weathertight and airtight seal. When electric heat is installed, use fire proof canvas (or similar heat resistant material) connector between ductwork and unit discharge connection. If flexible duct is used, insert a sheet metal sleeve inside duct. Heat resistant duct connector (or sheet metal sleeve) must extend 24-in. from the unit discharge connection flange into the ductwork.

**Table 1—Physical Data—Unit 50GS**

UNIT SIZE	018	024	030	036	042	048	060
NOMINAL CAPACITY (ton)	1-1/2	2	2-1/2	3	3-1/2	4	5
OPERATING WEIGHT (lb.)	254	260	258	268	294	324	389
COMPRESSOR	Reciprocating					Scroll	Reciprocating
REFRIGERANT (R-22) Quantity (lb.)	2.6	3.5	3.65	4.4	6.4	5.1	7.4
REFRIGERANT METERING DEVICE Orifice ID (in.)	Accurater						
	.034	.034	.034	.032	.034	.032	.030
CONDENSER COIL Rows...Fins/in. Face Area (sq. ft.)	1...17 6.1	1...17 9.1	1...17 9.1	1...17 10.9	1...17 9.1	1...17 12.3	2...17 12.3
CONDENSER FAN Nominal Cfm Diameter Motor Hp (Rpm)	2000 22 1/8 (825)	2400 22 1/8 (825)	2400 22 1/8 (825)	3000 18 1/4 (1100)	3000 22 1/4 (1100)	3600 22 1/4 (1100)	3600 22 1/4 (1100)
EVAPORATOR COIL Rows...Fins/in. Face Area (sq. ft.)	2...15 3.1	2...15 3.1	2...15 3.7	3...15 3.06	4...15 3.06	3...15 4.7	4...15 4.7
EVAPORATOR BLOWER Nominal Airflow (Cfm) Size (in.) Motor HP (RPM)	600 10x10 1/4 (825)	800 10x10 1/4 (1075)	1000 10x10 1/4 (1075)	1200 11x10 1/2 (1075)	1400 11x10 3/4 (1075)	1600 11x10 3/4 (1075)	2000 11x10 1.0 (1100)
RETURN-AIR FILTERS (in.)* Throwaway	20x20	20x20	20x20	20x24	20x24	24x30	24x30

\* Required filter sizes shown are based on the larger of the ARI (Air Conditioning and Refrigeration Institute) rated cooling airflow or the heating airflow velocity of 300 ft./min. for throwaway type or 450 ft./min. for high-capacity type. Air filter pressure drop for non-standard filters must not exceed 0.08 in. wg.

**Table 2—Physical Data—Unit 50GX**

UNIT SIZE	024	030	036	042	048	060
NOMINAL CAPACITY (ton)	2	2-1/2	3	3-1/2	4	5
OPERATING WEIGHT (lb.)	270	291	299	321	326	399
COMPRESSOR	Scroll					
REFRIGERANT (R-22) Quantity (lb.)	3.7	4.4	5.2	7.6	8.3	8.1
REFRIGERANT METERING DEVICE Orifice ID (in.)	Accurater					
	.034	.030	.032	.034	.034	.032
CONDENSER COIL Rows...Fins/in. Face Area (sq. ft.)	1...17 10.8	1...17 12.7	2...17 9.1	2...17 9.1	2...17 12.3	2...17 16.4
CONDENSER FAN Nominal Cfm Diameter (in.) Motor Hp (Rpm)	2350 22 1/8 (825)	2350 22 1/8 (825)	2350 22 1/8 (825)	3300 22 1/4 (1100)	3300 22 1/4 (1100)	3300 22 1/4 (1100)
EVAPORATOR COIL Rows...Fins/in. Face Area (sq. ft.)	3...15 3.1	3...15 3.1	3...15 3.7	3...15 4.7	4...15 4.7	4...15 4.7
EVAPORATOR BLOWER Nominal Airflow (Cfm) Size (in.) Motor Hp (RPM)	800 10x10 1/4 (1075)	1000 10x10 1/4 (1075)	1200 11x10 1/2 (1075)	1400 11x10 3/4 (1075)	1600 11x10 3/4 (1075)	1750 11x10 1.0 (1040)
RETURN-AIR FILTERS (in.)* Throwaway	20x20	20x20	20x24	20x30	24x30	24x30

\* Required filter sizes shown are based on the larger of the ARI (Air Conditioning and Refrigeration Institute) rated cooling airflow or the heating airflow velocity of 300 ft./min. for throwaway type or 450 ft./min. for high-capacity type. Air filter pressure drop for non-standard filters must not exceed 0.08 in. wg.

**CONFIGURING UNITS FOR DOWNFLOW (VERTICAL) DISCHARGE**

**⚠ WARNING**

Before performing service or maintenance operations on the system, turn off main power to unit and install lockout tag or electrical shock could result.

1. Open all electrical disconnects and install lockout tag before starting any service work.

2. Remove return duct cover located on duct panel by breaking four (4) connecting tabs with screwdriver and a hammer. (Fig. 8 & 9)
3. To remove supply duct cover, break front and right side connecting tabs with a screwdriver and a hammer. Push louver down to break rear and left side tabs. (Fig. 8 & 9)
4. If unit ductwork is to be attached to vertical opening flanges on the unit composite base (jackstand applications only), do so at this time. Collect ALL screws that were removed. Do not leave screws on rooftop as permanent damage to the roof may occur.



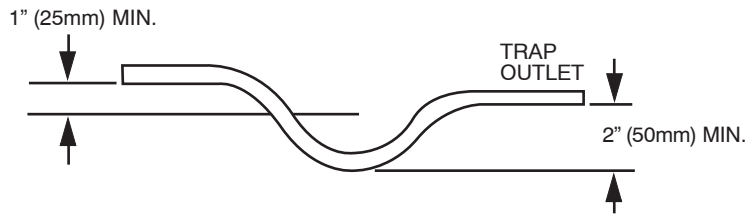

C99013

**Fig. 7—Condensate Trap**

**Table 3—Minimum Airflow for Safe Electric Heater Operation (Cfm)**

SIZE						
018	024	030	036	042	048	060
700	800	1000	1200	1400	1600	2000

5. It is recommended that the unit base insulation around the perimeter of the vertical return-air opening be secured to the unit base with aluminum tape. Applicable local codes may require aluminum tape to prevent exposed fiberglass.
6. Cover both horizontal duct openings with the duct covers from the accessory duct cover kit. Ensure opening is air-and watertight.
7. After completing unit conversion, perform all safety checks and power up unit.

**NOTE:** The design and installation of the duct system must be in accordance with the standards of the NFPA for installation of nonresidence-type air conditioning and ventilating systems, NFPA 90A or residence-type, NFPA 90B; and/or local codes and ordinances.

Adhere to the following criteria when selecting, sizing, and installing the duct system:

8. Units are shipped for side shot installation.
9. Select and size ductwork, supply-air registers, and return-air grilles according to American Society of Heating, Refrigeration and Air Conditioning Engineers (ASHRAE) recommendations.
10. Use flexible transition between rigid ductwork and unit to prevent transmission of vibration. The transition may be screwed or bolted to duct flanges. Use suitable gaskets to ensure weathertight and airtight seal.
11. All units must have field-supplied filters or accessory filter rack installed in the return-air side of the unit. Recommended sizes for filters are shown in Tables 1 and 2.
12. Size all ductwork for maximum required airflow (either heating or cooling) for unit being installed. Avoid abrupt duct size increases or decreases or performance may be affected.
13. Adequately insulate and weatherproof all ductwork located outdoors. Insulate ducts passing through unconditioned space, and use vapor barrier in accordance with latest issue of Sheet Metal and Air Conditioning Contractors National Association (SMACNA) and Air Conditioning Contractors of America (ACCA) minimum installation standards for heating and air conditioning systems. Secure all ducts to building structure.
14. Flash, weatherproof, and vibration-isolate all openings in building structure in accordance with local codes and good building practices.

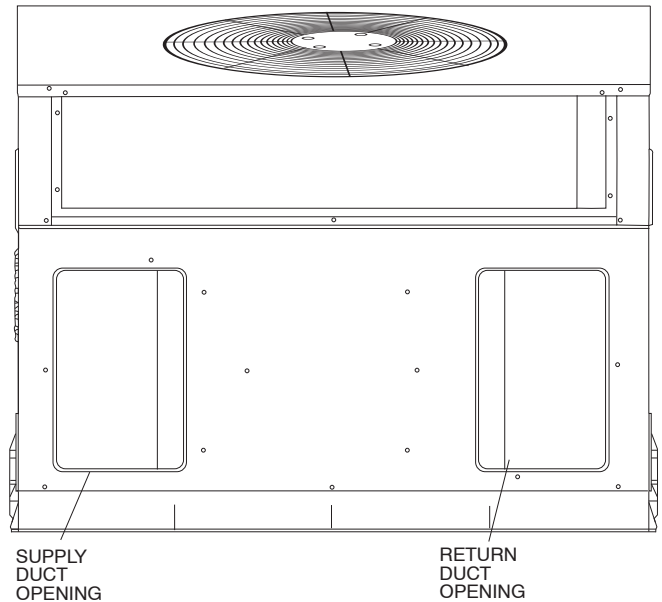

C99011

**Fig. 8—Supply and Return Duct Opening**  
**Step 8—Install Electrical Connection**

**⚠ WARNING**

The unit cabinet must have an uninterrupted, unbroken electrical ground to minimize the possibility of personal injury if an electrical fault should occur. This ground may consist of an electrical wire connected to the unit ground lug in the control compartment, or conduit approved for electrical ground when installed in accordance with NEC (National Electrical Code) ANSI/NFPA (latest edition) and local electrical codes. In Canada, follow Canadian Electrical Code CSA (Canadian Standards Association) C22.1 and local electrical codes. Failure to adhere to this warning could result in personal injury or death.

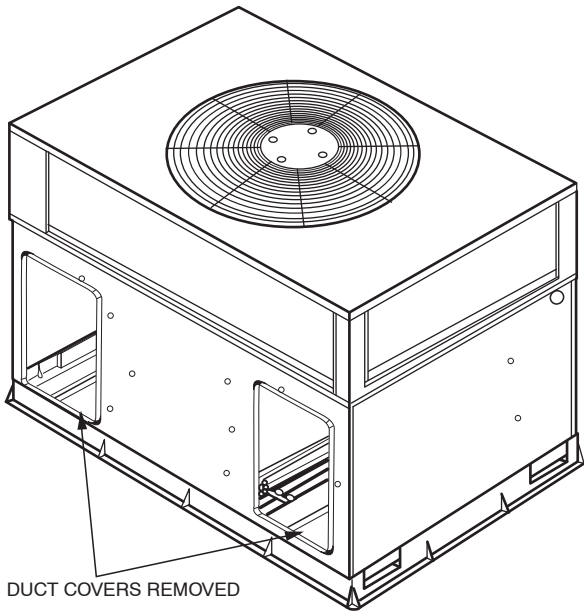

C99012

**Fig. 9—Vertical Duct Cover Removed**

**⚠ CAUTION**

Failure to follow these precautions could result in damage to the unit being installed:

1. Make all electrical connections in accordance with NEC ANSI/NFPA (latest edition) and local electrical codes governing such wiring. In Canada, all electrical connections must be in accordance with CSA standard C22.1 Canadian Electrical Code Part 1 and applicable local codes. Refer to unit wiring diagram.
2. Use only *copper* conductor for connections between field-supplied electrical disconnect switch and unit. **DO NOT USE ALUMINUM WIRE.**
3. Be sure that high-voltage power to unit is within operating voltage range indicated on unit rating plate.
4. Do not damage internal components when drilling through any panel to mount electrical hardware, conduit, etc. On 3-phase units, ensure phases are balanced within 2 percent. Consult local power company for correction of improper voltage and/or phase imbalance.

**HIGH-VOLTAGE CONNECTIONS**

The unit must have a separate electrical service with a field-supplied, waterproof, disconnect switch mounted at, or within sight from, the unit. Refer to the unit rating plate for maximum fuse/circuit breaker size and minimum circuit amps (ampacity) for wire sizing. See Tables 4 and 5 for electrical data.

The field-supplied disconnect switch box may be mounted on the unit over the high-voltage inlet hole when the standard power and low-voltage entry points are used. See Fig. 2 & 3 for acceptable location.

See unit wiring label and Fig. 10 for reference when making high voltage connections. Proceed as follows to complete the high-voltage connections to the unit.

Single phase units:

1. Run the high-voltage (L1, L2) and ground leads into the control box.
2. Connect ground lead to chassis ground connection.
3. Connect L1 to pressure lug connection 11 of the compressor contactor.

4. Connect L2 to pressure lug connection 23 of the compressor contactor.

Three phase units:

1. Run the high-voltage (L1, L2, L3) and ground leads into the control box.
2. Connect ground lead to chassis ground connection.
3. Locate the black and yellow wires connected to the lines side of the contactor.
4. Connect field L1 to black wire on connection 11 of the compressor contactor.
5. Connect field wire L2 to yellow wire on connection 13 of the compressor contactor.
6. Connect field wire L3 to Blue wire from compressor.

**SPECIAL PROCEDURES FOR 208-V OPERATION**

**⚠ WARNING**

Make sure that the power supply to the unit is switched OFF and lockout tag installed before making any wiring changes. Electrical shock can cause serious injury or death.

**CONTROL VOLTAGE CONNECTIONS**

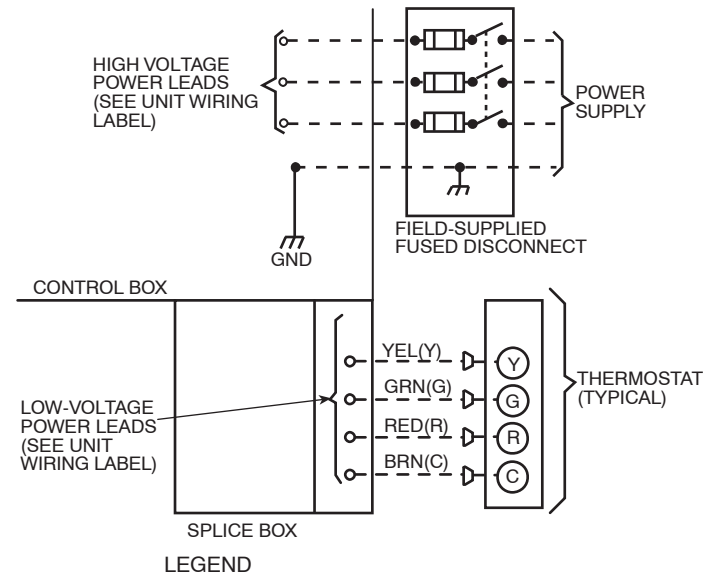

NOTE: Use blue wire for 3-phase units only.

C99010

**Fig. 10—High- and Control-Voltage Connections**

**NOTE:** Do not use any type of power-stealing thermostat. Unit control problems may result.

Use no. 18 American Wire Gage (AWG) color-coded, insulated (35 C minimum) wires to make the control voltage connections between the thermostat and the unit. If the thermostat is located more than 100 ft. from the unit (as measured along the control voltage wires), use no. 16 AWG color-coded, insulated (35 C minimum) wires.

**STANDARD CONNECTION**

Remove knockout hole located in the electric heat panel adjacent to the control access panel. See Fig. 2 & 3. Remove the rubber grommet from the installer's packet (included with unit) and install grommet in the knockout opening. Provide a drip loop before running wire through panel.

**Table 4—Electrical Data—50GS**

UNIT 50GS SIZE	V-PH-HZ	VOLTAGE RANGE		COMPRESSOR		OFM	IFM	ELECTRIC HEAT		POWER SUPPLY		
		Min	Max	RLA	LRA	FLA	FLA	Nominal Kw*	FLA	MCA	Max Fuse orCkt Bkr	MOCP
018	208/230-1-60	187	254	9	45	0.8	1.8	-/-	-/-	13.9/13.9	20/20	—
								3.8/5.0	18.1/20.8	24.8/28.3	25/30	—
								5.4/7.2	26.0/30.0	34.7/39.8	35/40	—
								7.5/10.0	36.1/41.7	47.4/54.3	50/60	—
024	208/230-1-60	187	254	12.8	61	0.8	2	-/-	-/-	18.8/18.8	25/25	—
								3.8/5.0	18.1/20.8	25.1/28.5	25/30	—
								5.4/7.2	2/30	35/40	35/40	—
								7.5/10.0	36.1/41.7	47.6/54.6	50/60	—
030	208/230-1-60	187	254	14.4	73	0.8	2	-/-	-/-	20.8/20.8	25/25	—
								3.8/5.0	18.1/20.8	25.1/28.5	25/30	—
								5.4/7.2	26.0/30.0	35/40	35/40	—
								7.5/10.0	36.1/41.7	47.6/54.6	50/60	—
	208/230-3-60	187	254	8.3	68	0.8	2	-/-	-/-	13.2/13.2	20/20	—
								3.8/5.0	10.4/12.0	15.5/17.5	20/20	—
								7.5/10.0	20.8/24.1	28.6/32.6	30/35	—
								11.3/15.0	31.3/36.1	41.6/47.6	45/50	—
036	208/230-1-60	187	254	15.0	82	1.4	4.1	-/-	-/-	24.3/24.3	30/30	—
								3.8/5.0	18.1/20.8	27.7/31.2	30/35	—
								5.4/7.2	26.0/30.0	37.6/42.6	40/45	—
								7.5/10.0	36.1/41.7	50.3/57.2	60/60	—
	208/230-3-60	187	254	9.0	78	1.4	4.1	-/-	-/-	16.8/16.8	20/20	—
								3.8/5.0	10.4/12.0	18.2/20.2	20/20	—
								7.5/10.0	20.8/24.1	31.2/35.2	35/40	—
								11.3/15.0	31.3/36.1	44.2/50.2	45/60	—
	460-3-60	414	508	4.5	40	0.8	1.4	-	-	7.8	15	—
								5	6	9.3	15	—
								10	12	16.8	20	—
								15	18	24.3	25	—
042	208/230-1-60	187	254	18.6	105	1.4	4	-/-	-/-	28.7/28.7	35/35	—
								3.8/5.0	18.1/20.8	28.7/31.0	35/35	—
								5.4/7.2	26.0/30.0	37.5/42.5	40/45	—
								7.5/10.0	36.1/41.7	50.1/57.1	60/60	—
	208/230-3-60	187	254	10.7	85	1.4	4	-/-	-/-	18.8/18.8	25/25	—
								3.8/5.0	10.4/12.0	18.8/20.0	25/25	—
								7.5/10.0	20.8/24.1	31.1/35.1	35/40	—
								11.3/15.0	31.3/36.1	44.1/50.1	45/60	—
	460-3-60	414	508	5.3	42	0.8	2	-	-	9.4	15	—
								5	6	10.0	15	—
								10	12	17.5	20	—
								15	18	25.1	30	—
048	208/230-1-60	187	254	25.3	131	2.1	5	-/-	-/-	38.7/38.7	40/40	—
								3.8/5.0	18.1/20.8	38.7/38.7	40/40	—
								5.4/7.2	26.0/30.0	38.7/43.8	40/45	—
								7.5/10.0	36.1/41.7	51.4/58.3	60/60	—
	208/230-3-60	187	254	14.6	108	2.1	5	-/-	-/-	25.4/25.4	30/30	—
								3.8/5.0	10.4/12.0	25.4/25.4	30/30	—
								7.5/10.0	20.8/24.1	32.3/36.3	35/40	—
								11.3/15.0	31.3/36.1	45.3/51.4	50/60	—
	460-3-60	414	508	7.3	48	1.1	2.3	-	-	12.5	15	—
								5	6	12.5	15	—
								10	12	17.9	20	—
								15	18	25.4	30	—
060	208/230-1-60	187	254	28.9	147	2.1	6.8	-/-	-/-	45.0/45.0	60/60	—
								3.8/5.0	18.1/20.8	45.0/45.0	60/60	—
								5.4/7.2	26.0/30.0	45.0/46.0	45/50	—
								7.5/10.0	36.1/41.7	53.6/60.6	—	60/70
	208/230-3-60	187	254	18.6	125	2.1	6.8	-/-	-/-	32.2/32.2	40/40	—
								3.8/5.0	10.4/12.0	32.2/32.2	35/35	—
								7.5/10.0	20.8/24.1	34.6/38.6	35/35	—
								11.3/15.0	31.3/36.1	47.6/53.6	50/60	—
	460-3-60	414	508	8.5	66.5	1.1	3.2	-	-	14.9	20	—
								5	6	14.9	15	—
								10	12	19.0	15	—
								15	18	26.6	30	—
								20	35	—		

(See legend following Electrical Data charts)

**Table 5—Electrical Data—50GX**

UNIT 50GX SIZE	V-PH-HZ	VOLTAGE RANGE		COMPRESSOR		OFM	IFM	ELECTRIC HEAT		POWER SUPPLY		
		Min	Max	RLA	LRA	FLA	FLA	Nominal Kw*	FLA	MCA	Max Fuse or Ckt Bkr	MOCP
024	208/230-1-60	187	253	10.9	54.0	0.9	2.0	-/- 3.8/5.0 5.4/7.2 7.5/10.0	-/- 18.1/20.8 26.0/30.0 36.1/41.7	16.5/16.5 25.1/28.5 35.0/40.0 47.6/54.6	20/20 30/30 35/40 50/60	— — — —
030	208/230-1-60	187	253	13.5	73.0	0.8	2.1	-/- 3.8/5.0 5.4/7.2 7.5/10.0 11.3/15.0	-/- 18.1/20.8 26.0/30.0 36.1/41.7 54.2/62.5	19.8/19.8 25.2/28.7 35.1/40.1 47.8/54.7 70.3/80.8	25/25 25/30 40/45 50/60 —	— — — — 80/90
	208/230-3-60	187	253	9.0	63.0	0.8	2.1	-/- 3.8/5.0 7.5/10.0 11.3/15.0	-/- 10.4/12.0 20.8/24.1 31.3/36.1	14.2/14.2 15.7/17.7 28.7/32.7 41.7/47.7	20/20 20/20 30/35 45/50	— — — —
036	208/230-1-60	187	253	16.7	97.0	0.8	4.1	-/- 3.8/5.0 5.4/7.2 7.5/10.0 11.3/15.0	-/- 18.1/20.8 26.0/30.0 36.1/41.7 54.2/62.5	25.8/25.8 27.7/31.2 37.6/42.6 50.3/57.2 72.8/83.3	30/30 30/35 40/45 60/60 —	— — — — 80/90
	208/230-3-60	187	253	11.2	75.0	0.8	4.1	-/- 3.8/5.0 7.5/10.0 11.3/15.0	-/- 10.4/12.0 20.8/24.1 31.3/36.1	18.9/18.9 18.9/20.2 31.0/35.2 44.2/50.2	25/25 25/25 35/40 45/60	— — — —
	460-3-60	414	506	5.4	37.5	0.9	1.9	- 5 10 15	-/- 6 12 18	9.6 9.9 17.4 24.9	15 15 20 25	— — — —
042	208/230-1-60	187	253	17.9	104.0	1.6	4.1	-/- 3.8/5.0 5.4/7.2 7.5/10.0 11.3/15.0 15.0/20.0	-/- 18.1/20.8 26.0/30.0 36.1/41.7 54.2/62.5 72.2/83.3	28.1/28.1 28.1/31.2 37.6/42.6 50.3/57.2 72.8/83.3 95.4/109.3	35/35 35/35 40/45 60/60 — —	— — — — 80/90 100/110
	208/230-3-60	187	253	12.4	88.0	1.6	4.1	-/- 3.8/5.0 7.5/10.0 11.3/15.0 15.0/20.0	-/- 10.4/12.0 20.8/24.1 31.3/36.1 41.7/48.1	21.2/21.2 21.2/21.2 31.2/35.2 44.2/50.2 57.2/65.3	25/25 25/25 35/40 45/60 —	— — — — 60/70
	460-3-60	414	506	6.1	44.0	0.9	2.0	- 5 10 15 20	-/- 6.0 12.0 18.0 24.1	10.5 10.5 17.5 25.1 32.6	15 15 20 30 35	— — — — —
048	208/230-1-60	187	253	23.4	126.0	1.5	4.1	-/- 3.8/5.0 5.4/7.2 7.5/10.0 11.3/15.0 15.0/20.0	-/- 18.1/20.8 26.0/30.0 36.1/41.7 54.2/62.5 72.2/83.3	34.9/34.9 34.9/34.9 37.6/42.6 50.3/57.2 72.8/83.3 95.4/109.3	45/45 35/35 40/45 60/60 — —	— — — — 80/90 100/110
	208/230-3-60	187	253	13.0	93.0	1.5	4.1	-/- 3.8/5.0 7.5/10.0 11.3/15.0 15.0/20.0	-/- 10.4/12.0 20.8/24.1 31.3/36.1 41.7/48.1	21.9/21.9 21.9/21.9 31.2/35.2 44.2/50.2 57.2/65.3	30/30 25/25 35/40 45/60 —	— — — — 60/70
	460-3-60	414	506	6.4	46.5	0.9	1.9	- 5 10 15 20	-/- 6.0 12.0 18.0 24.1	10.8 10.8 17.4 24.9 32.4	15 15 20 25 35	— — — — —
060	208/230-1-60	187	253	28.8	169.0	1.6	6.2	-/- 3.8/5.0 5.4/7.2 7.5/10.0 11.3/15.0 15.0/20.0	-/- 18.1/20.8 26.0/30.0 36.1/41.7 54.2/62.5 72.2/83.3	43.8/43.8 43.8/43.8 40.2/45.3 52.9/59.8 75.4/85.9 98.0/111.9	60/60 45/45 45/50 60/60 — —	— — — — 80/90 100/125
	208/230-3-60	187	253	17.3	123.0	1.6	6.2	-/- 3.8/5.0 7.5/10.0 11.3/15.0 15.0/20.0	-/- 10.4/12.0 20.8/24.1 31.3/36.1 41.7/48.1	29.4/29.4 29.4/29.4 33.8/37.8 46.8/52.9 59.9/67.9	35/35 30/30 30/40 50/60 —	— — — — 60/70
	460-3-60	414	506	9.0	62.0	0.9	3.2	- 5 10 15 20	-/- 6.0 12.0 18.0 24.1	15.4 15.4 19.0 26.6 34.1	20 20 15 30 35	— — — — —

(See legend following Electrical Data charts)

- LEGEND
- FLA — Full Load Amps
  - LRA — Locked Rotor Amps
  - MCA — Minimum Circuit Amps
  - MOCP — Maximum Overcurrent Protection
  - RLA — Rated Load Amps
  - CKT BKR — Circuit Breaker



NOTES:

1. In compliance with NEC (National Electrical Code) requirements for multimotor and combination load equipment (refer to NEC Articles 430 and 440), the overcurrent protective device for the unit shall be Power Supply fuse. Canadian units may be fuse or circuit breaker.
2. Minimum wire size is based on 60 C copper wire. If other than 60 C wire is used, or if length exceeds wire length in table, determine size from NEC.
3. Unbalanced 3-Phase Supply Voltage  
*Never operate a motor where a phase imbalance in supply voltage is greater than 2%.* Use the following formula to determine the percentage of voltage imbalance.

% Voltage imbalance

$$= 100 \times \frac{\text{max voltage deviation from average voltage}}{\text{average voltage}}$$

Run the low-voltage leads from the thermostat, through the inlet hole, and into unit low-voltage splice box.

Locate five 18-gage wires leaving control box. These low-voltage connection leads can be identified by the colors red, green, yellow, brown, and white (See Fig. 10). Ensure the leads are long enough to be routed into the low-voltage splice box (located below right side of control box). Stripped yellow wire is located in connection box. Route leads through hole in bottom of control box and make low-voltage connections (See Fig. 10). Secure all cut wires, so that they do not interfere with operation of unit.

TRANSFORMER PROTECTION

The *transformer* is of the energy-limiting type. It is set to withstand a 30-second overload or shorted secondary condition.

EXAMPLE: Supply voltage is 460-3-60.

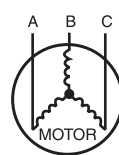

AB = 452 v  
BC = 464 v  
AC = 455 v

$$\begin{aligned} \text{Average Voltage} &= \frac{452 + 464 + 455}{3} \\ &= \frac{1371}{3} \\ &= 457 \end{aligned}$$

Determine maximum deviation from average voltage.

(AB) 457 452 = 5 v  
(BC) 464 457 = 7 v  
(AC) 457 455 = 2 v

Maximum deviation is 7 v.

Determine percent of voltage imbalance.

$$\begin{aligned} \% \text{ Voltage Imbalance} &= 100 \times \frac{7}{457} \\ &= 1.53\% \end{aligned}$$

This amount of phase imbalance is satisfactory as it is below the maximum allowable 2%.

**IMPORTANT:** If the supply voltage phase imbalance is more than 2%, contact your local electric utility company immediately.

C99024

PRE-START-UP

**⚠ WARNING**

Failure to observe the following warnings could result in serious personal injury:

1. Follow recognized safety practices and wear protective goggles when checking or servicing refrigerant system.
2. Do not operate compressor or provide any electric power to unit unless compressor terminal cover is in place and secured.
3. Do not remove compressor terminal cover until all electrical sources are disconnected.
4. Relieve and recover all refrigerant from system before touching or disturbing anything inside terminal box if refrigerant leak is suspected around compressor terminals.
5. Never attempt to repair soldered connection while refrigerant system is under pressure.
6. Do not use torch to remove any component. System contains oil and refrigerant under pressure. To remove a component, wear protective goggles and proceed as follows:
  - a. Shut off electrical power to unit.
  - b. Relieve and reclaim all refrigerant from system using both high- and low-pressure ports.
  - c. Cut component connecting tubing with tubing cutter and remove component from unit.
  - d. Carefully unsweat remaining tubing stubs when necessary. Oil can ignite when exposed to torch flame.

Proceed as follows to inspect and prepare the unit for initial startup:

1. Remove access panel.
2. Read and follow instructions on all WARNING, CAUTION, and INFORMATION labels attached to, or shipped with, unit.
3. Make the following inspections:
  - a. Inspect for shipping and handling damages such as broken lines, loose parts, disconnected wires, etc.
  - b. Inspect for oil at all refrigerant tubing connections and on unit base. Detecting oil generally indicates a refrigerant

leak. Leak test all refrigerant tubing connections using electronic leak detector, halide torch, or liquid-soap solution. If a refrigerant leak is detected, see Check for Refrigerant Leaks section.

- c. Inspect all field- and factory-wiring connections. Be sure that connections are completed and tight.
- d. Ensure electrical wiring does not contact refrigerant tubes or sharp metal edges.
- e. Inspect coil fins. If damaged during shipping and handling, carefully straighten fins with a fin comb.

Verify the following conditions:

- a. Make sure that condenser-fan blade is correctly positioned in fan orifice. Leading edge of condenser-fan blade should be 1/2 in. maximum from fan orifice (See Fig. 11).
- b. Make sure that air filter(s) is in place.
- c. Make sure that condensate drain trap is filled with water to ensure proper drainage.
- d. Make sure that all tools and miscellaneous loose parts have been removed.

### START-UP

#### CHECK FOR REFRIGERANT LEAKS

Proceed as follows to locate and repair a refrigerant leak and to charge the unit:

1. Locate leak and make sure that refrigerant system pressure has been relieved and reclaimed from both high- and low-pressure ports.

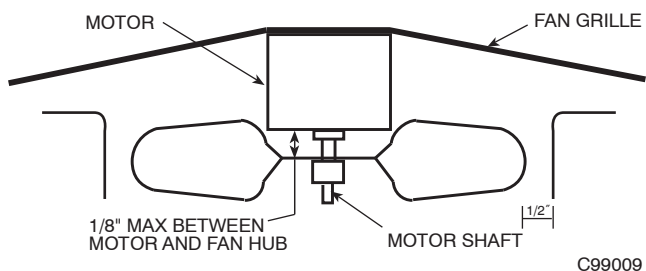

**Fig. 11—Fan Blade Clearance**

2. Repair leak following accepted practices. **NOTE:** Install a filter drier whenever the system has been opened for repair.
3. Add a small charge of R-22 refrigerant vapor to system and leak-test unit.
4. Recover refrigerant from refrigerant system and evacuate to 500 microns if no additional leaks are not found.
5. Charge unit with R-22 refrigerant, using a volumetric-charging cylinder or accurate scale. *Refer to unit rating plate for required charge.* Be sure to add extra refrigerant to compensate for internal volume of filter drier.

### START UP COOLING SECTION AND MAKE ADJUSTMENTS

#### CAUTION

Complete the required procedures given in the Pre-Start-Up section before starting the unit. Do not jumper any safety devices when operating the unit. Do not operate the compressor when the outdoor temperature is below 40°F (unless accessory low-ambient kit is installed). Do not rapid-cycle the compressor. Allow 5 minutes between “on” cycles to prevent compressor damage.

#### CHECKING COOLING CONTROL OPERATION

Start and check the unit for proper cooling control operation as follows:

1. Place room thermostat SYSTEM switch in OFF position. Observe that blower motor starts when FAN switch is placed in ON position and shuts down after 30 second fan time delay expires when FAN switch is placed in AUTO position.
2. Place SYSTEM switch in COOL position and FAN switch in AUTO position. Set cooling control below room temperature. Observe that compressor, condenser fan, and evaporator blower motors start. Observe that compressor and outdoor fan shut down when control setting is satisfied and that indoor blower shuts down after 30 second fan time delay expires.
3. When using an auto-changeover room thermostat, place both SYSTEM and FAN switches in AUTO positions. Observe that unit operates in heating mode when temperature control is set to “call for heating” (above room temperature) and operates in cooling mode when temperature control is set to “call for cooling” (below room temperature).

**IMPORTANT:** Three-phase, scroll compressor units (50GS048, 50GX030-060) are direction-oriented. These units must be checked to ensure proper compressor 3-phase power lead orientation. If not corrected within 5 minutes, the internal protector will shut off the compressor. The 3-phase power leads to the unit must be reversed to correct rotation. When turning backwards, scroll compressors emit elevated noise levels, and the difference between compressor suction and discharge pressures may be dramatically lower than normal.

#### CHECKING AND ADJUSTING REFRIGERANT CHARGE

The refrigerant system is fully charged with R-22 refrigerant, tested, and factory-sealed.

**NOTE:** Adjustment of the refrigerant charge is not required unless the unit is suspected of not having the proper R-22 charge. A superheat charging chart is attached to the outside of the service access panel. The chart includes the required suction line temperature at given suction line pressures and outdoor ambient temperatures (See Fig. 15–27).

An accurate superheat, thermocouple- or thermistor-type thermometer, a sling psychrometer, and a gauge manifold are required when using the superheat charging method for evaluating the unit charge. *Do not use mercury or small dial-type thermometers because they are not adequate for this type of measurement.*

**NOTE:** Allow system to operate in the cooling mode for a minimum of 10 minutes before checking or adjusting refrigerant charge.



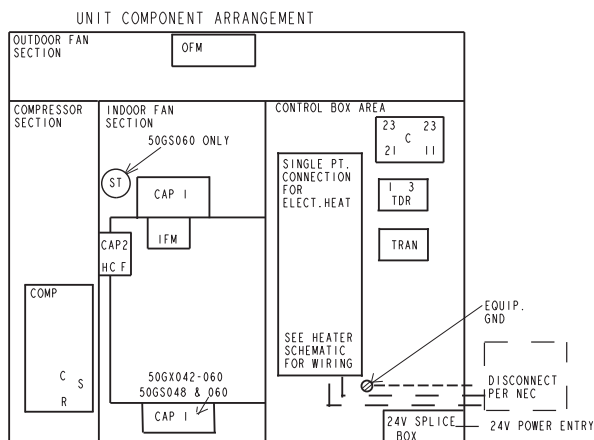
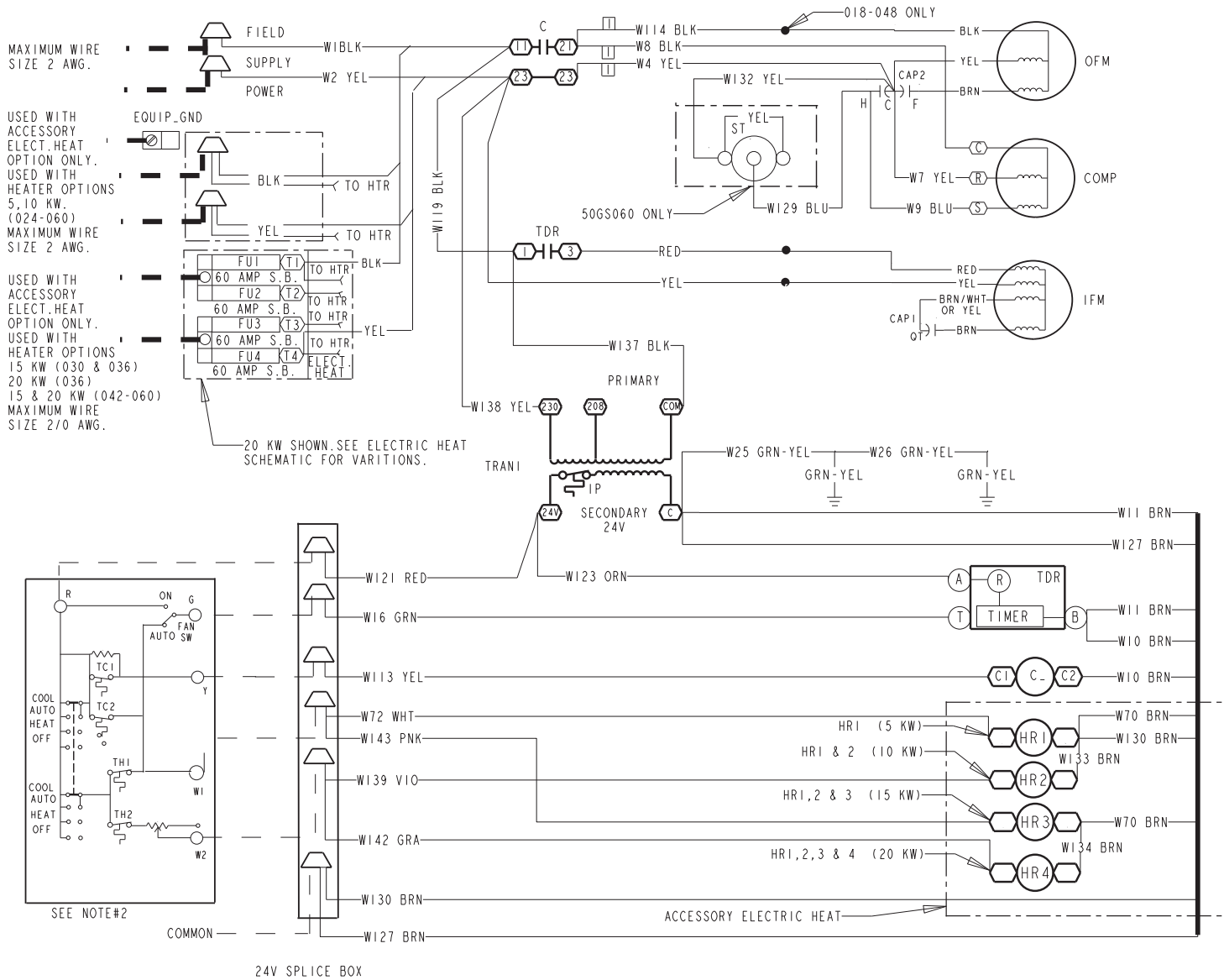

LEGEND

- |  |                       |                        |
|--|-----------------------|------------------------|
| △ FIELD SPLICE   | C CONTACTOR           | TDR (1,3) FAN SEQUENCE |
| ○ TERMINAL (MARKED)  | CAP CAPACITOR         | 0 ENERGIZED            |
| ○ TERMINAL (UNMARKED)  | COMP COMPRESSOR MOTOR | 1 DE-ENERGIZED         |
| ● SPLICE   | EQUIP EQUIPMENT       | T+30                   |
| ○ SPLICE (MARKED)  | FU FUSE               |                        |
| — FACTORY WIRING   | GND GROUND            |                        |
| - - - FIELD CONTROL WIRING                                   | HR HEATER RELAY       |                        |
| - - - FIELD POWER WIRING                                     | HTR HEATER            |                        |
| - - - ACCESSORY OR OPTIONAL WIRING                           | IFM INDOOR FAN MOTOR  |                        |
| — TO INDICATE COMMON POTENTIAL ONLY; NOT TO REPRESENT WIRING | IP INTERNAL PROTECTOR |                        |
|  | OFM OUTDOOR FAN MOTOR |                        |
|  | QT QUADRUPLE TERMINAL |                        |
|  | S.B. SLOW BLOW FUSE   |                        |
|  | ST THERMISTOR START   |                        |
|  | TC THERMOSTAT-COOLING |                        |
|  | TDR TIME DELAY RELAY  |                        |
|  | TH THERMOSTAT-HEATING |                        |
|  | TRAN TRANSFORMER      |                        |

NOTES:

1. IF ANY OF THE ORIGINAL WIRES FURNISHED ARE REPLACED, IT MUST BE REPLACED WITH TYPE 90 DEGREE C WIRE OR IT'S EQUIVALENT.
2. SEE PRICE PAGES FOR THERMOSTAT AND SUBBASES.
3. USE 75 DEGREE COPPER CONDUCTORS FOR FIELD INSTALLATION.
4. FOR HIGH SPEED IFM, DISCONNECT RED WIRE FROM TDR; 3 AND CONNECT BLK WIRE FROM IFM. FOR MEDIUM SPEED, DISCONNECT RED WIRE FROM TDR; 3 AND CONNECT BLU WIRE FROM IFM.

C99003

Fig. 12—Wiring Diagram (208/230-60-1)

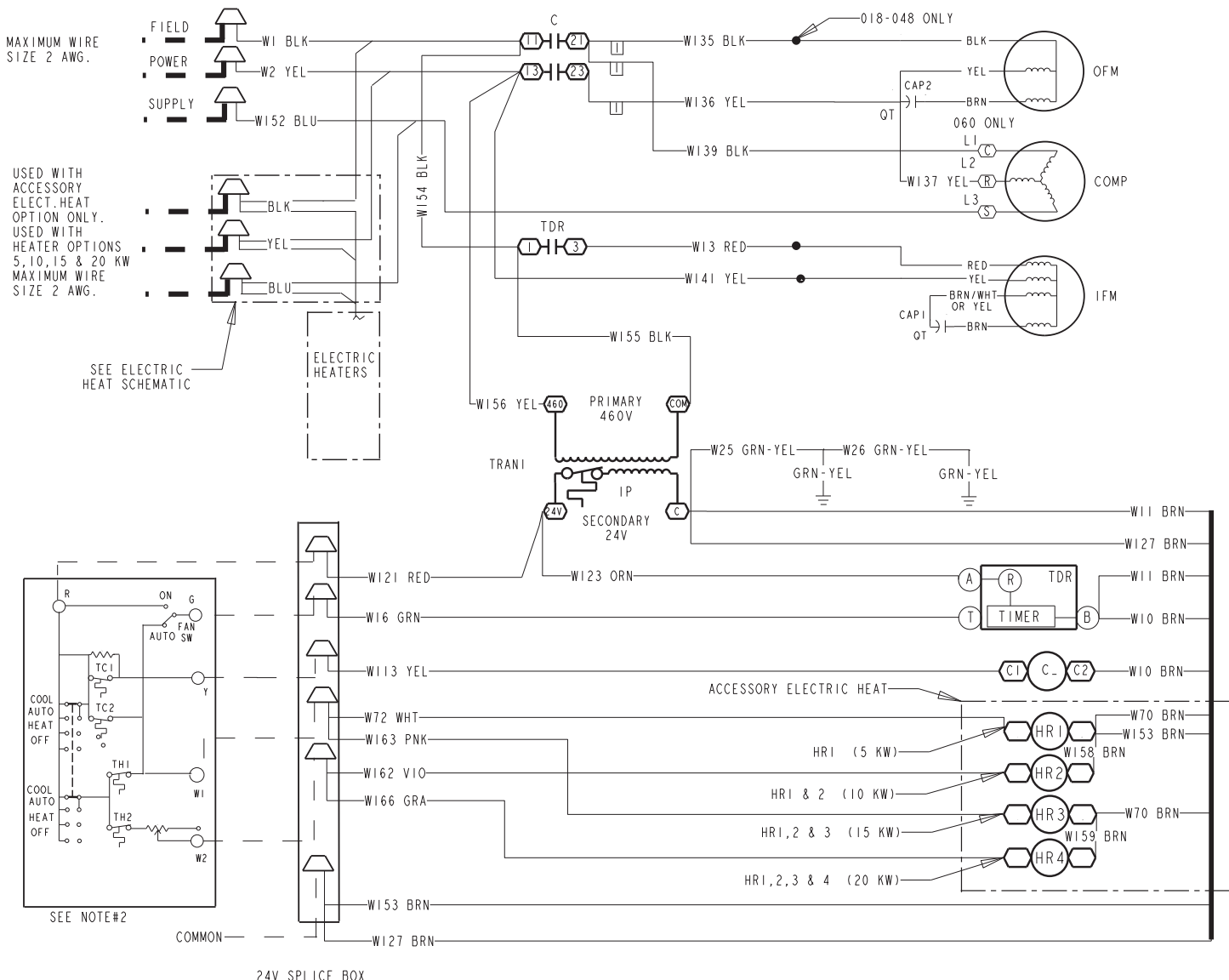

**LEGEND**

- △ FIELD SPLICE
- TERMINAL (MARKED)
- TERMINAL (UNMARKED)
- SPLICE
- SPLICE (MARKED)
- FACTORY WIRING
- - - FIELD CONTROL WIRING
- - - FIELD POWER WIRING
- - - ACCESSORY OR OPTIONAL WIRING
- TO INDICATE COMMON
- POTENTIAL ONLY: NOT TO REPRESENT WIRING
- C CONTACTOR
- CAP CAPACITOR
- COMP COMPRESSOR MOTOR
- EQUIP EQUIPMENT
- GND GROUND
- HR HEATER RELAY
- IFM INDOOR FAN MOTOR
- IP INTERNAL PROTECTOR
- OFM OUTDOOR FAN MOTOR
- QT QUADRUPLE TERMINAL
- TC THERMOSTAT-COOLING
- TDR TIME DELAY RELAY
- TH THERMOSTAT-HEATING
- TRAN TRANSFORMER

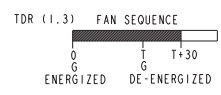

**UNIT COMPONENT ARRANGEMENT**

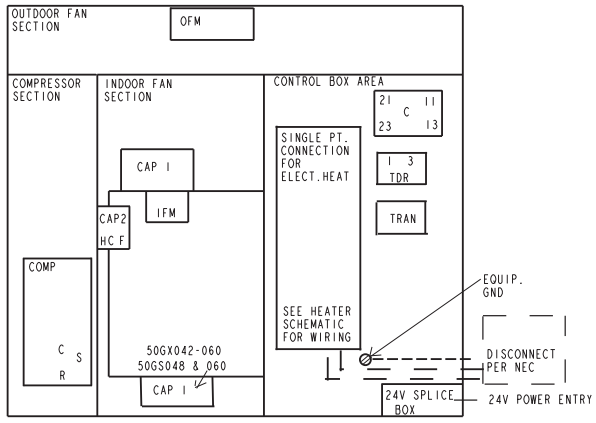

- NOTES:**
- IF ANY OF THE ORIGINAL WIRES FURNISHED ARE REPLACED, IT MUST BE REPLACED WITH TYPE 90 DEGREE C WIRE OR IT'S EQUIVALENT.
  - SEE PRICE PAGES FOR THERMOSTAT AND SUBBASES.
  - USE 75 DEGREE COPPER CONDUCTORS FOR FIELD INSTALLATION.
  - FOR HIGH SPEED IFM, DISCONNECT RED WIRE FROM TDR;3 AND CONNECT BLK WIRE FROM IFM. FOR MEDIUM SPEED, DISCONNECT RED WIRE FROM TDR;3 AND CONNECT BLU WIRE FROM IFM.

C99004

**Fig. 13—Wiring Diagram (208/230-60-3)**

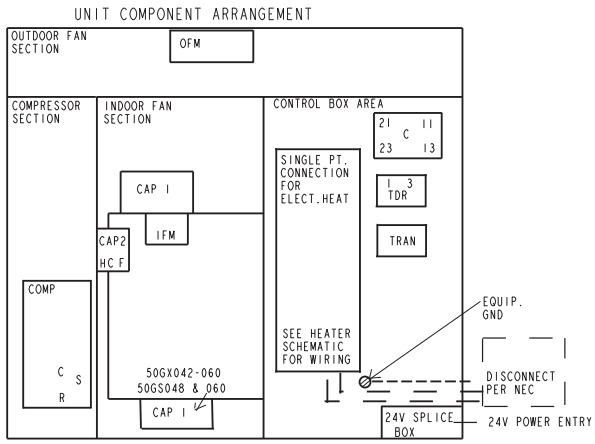
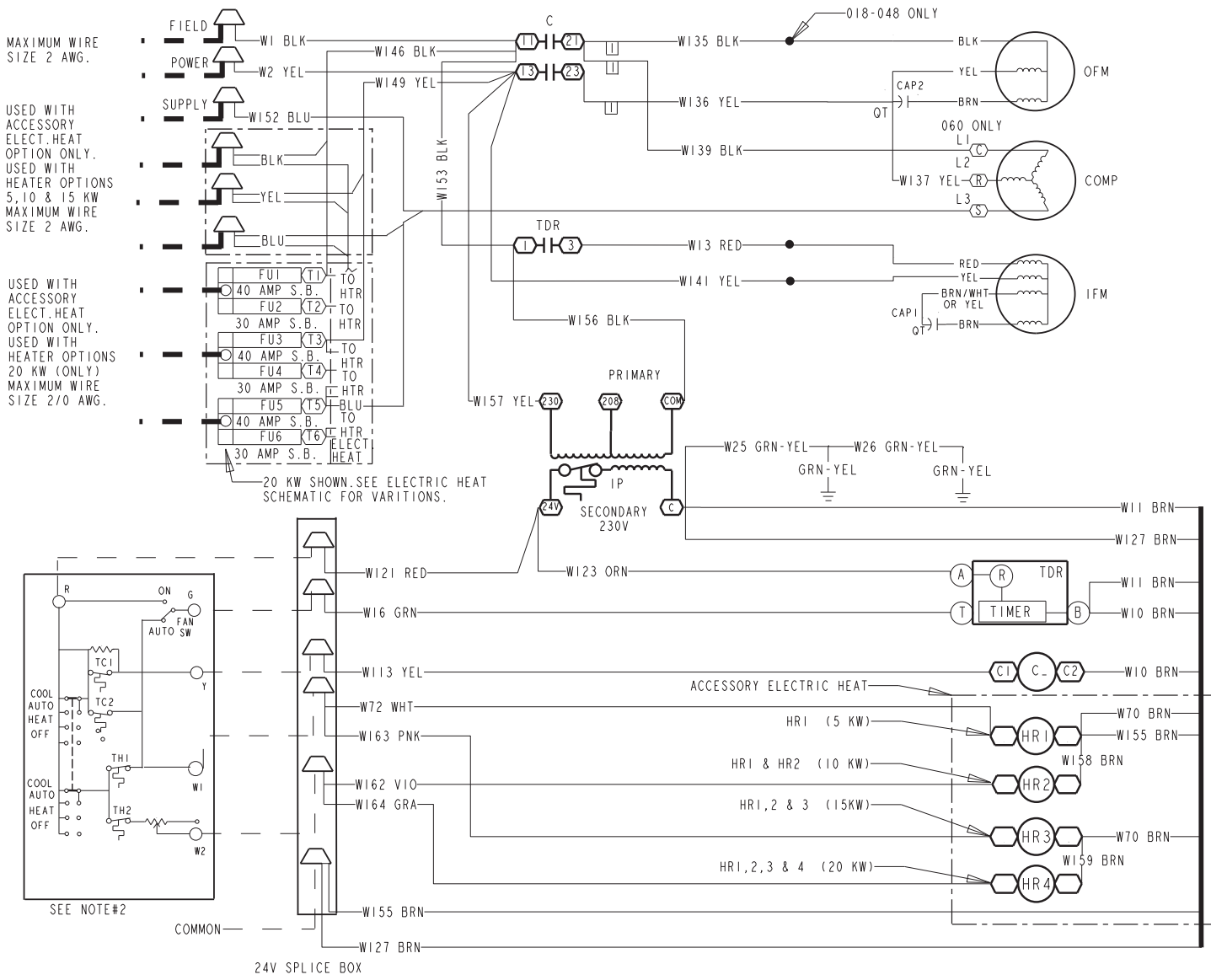

**LEGEND**

- |  |                       |  |
|--|-----------------------|--|
| △ FIELD SPLICE   | C CONTACTOR           |  |
| ○ TERMINAL (MARKED)  | CAP CAPACITOR         |  |
| ○ TERMINAL (UNMARKED)  | COMP COMPRESSOR MOTOR |  |
| ● SPLICE   | EQUIP EQUIPMENT       |  |
| ○ SPLICE (MARKED)  | FU FUSE               |  |
| — FACTORY WIRING   | GND GROUND            |  |
| - - - FIELD CONTROL WIRING                                   | HR HEATER RELAY       |  |
| - - - FIELD POWER WIRING                                     | HTR HEATER            |  |
| - - - ACCESSORY OR OPTIONAL WIRING                           | IFM INDOOR FAN MOTOR  |  |
| — TO INDICATE COMMON POTENTIAL ONLY: NOT TO REPRESENT WIRING | IP INTERNAL PROTECTOR |  |
|  | OFM OUTDOOR FAN MOTOR |  |
|  | QT QUADRUPLE TERMINAL |  |
|  | S.B. SLOW BLOW FUSE   |  |
|  | TC THERMOSTAT-COOLING |  |
|  | TDR TIME DELAY RELAY  |  |
|  | TH THERMOSTAT-HEATING |  |
|  | TRAN TRANSFORMER      |  |
- NOTES:
1. IF ANY OF THE ORIGINAL WIRES FURNISHED ARE REPLACED, IT MUST BE REPLACED WITH TYPE 90 DEGREE C WIRE OR IT'S EQUIVALENT.
  2. SEE PRICE PAGES FOR THERMOSTAT AND SUBBASES.
  3. USE 75 DEGREE COPPER CONDUCTORS FOR FIELD INSTALLATION.
  4. FOR HIGH SPEED IFM, DISCONNECT RED WIRE FROM TDR; 3 AND CONNECT BLK WIRE FROM IFM. FOR MEDIUM SPEED, DISCONNECT RED WIRE FROM TDR; 3 AND CONNECT BLU WIRE FROM IFM.

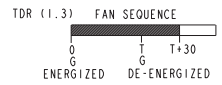

**Fig. 14—Wiring Diagram (460-60-3)**

C99005

### ⚠ CAUTION

When evaluating the refrigerant charge, an indicated adjustment to the specified factory charge must always be very minimal. If a substantial adjustment is indicated, an abnormal condition exists somewhere in the cooling system, such as insufficient airflow across either coil or both coils.

Proceed as follows:

1. Remove caps from low- and high-pressure service fittings.
2. Using hoses with valve core depressors, attach low- and high-pressure gauge hoses to low- and high-pressure service fittings, respectively.
3. Start unit in Cooling mode and let unit run until system pressures stabilize.
4. Measure and record the following:
  - a. Outdoor ambient-air temperature (°F db).
  - b. Evaporator inlet-air temperature (°F wb).
  - c. Suction-tube temperature (°F) at low-side service fitting.
  - d. Suction (low-side) pressure (psig).
5. Using “Cooling Charging Charts” compare outdoor-air temperature (°F db) with the suction line pressure (psig) to determine desired system operating suction line temperature. See Fig. 15-27.
6. Compare actual suction-tube temperature with desired suction-tube temperature. Using a tolerance of  $\pm 3^{\circ}\text{F}$ , add refrigerant if actual temperature is more than  $3^{\circ}\text{F}$  higher than proper suction-tube temperature, or remove refrigerant if actual temperature is more than  $3^{\circ}\text{F}$  lower than required suction-tube temperature.

**NOTE:** If the problem causing the inaccurate readings is a refrigerant leak, refer to Check for Refrigerant Leaks section.

#### INDOOR AIRFLOW AND AIRFLOW ADJUSTMENTS

### ⚠ CAUTION

For cooling operation, the recommended airflow is 350 to 450 cfm for each 12,000 Btuh of rated cooling capacity.

Tables 8 and 9 show cooling airflows at various external static pressures. Refer to these tables to determine the airflow for the system being installed.

**NOTE:** Be sure that all supply- and return-air grilles are open, free from obstructions, and adjusted properly.

### ⚠ WARNING

Disconnect electrical power to the unit and install lockout tag before changing blower speed. Electrical shock can cause serious injury or death.

Airflow can be changed by changing the lead connections of the blower motor.

Unit 50GS two- or three-speed motors (except size 030) are factory wired for low speed operation. Unit 50GS030 is factory wired for medium speed.

All 50GX units are factory wired for low speed and may need to be wired for medium or high speed in the field.

FOR 208/230V

For color coding on the 208/230V motor leads, see Table 6.

To change the speed of the indoor fan motor (IFM), remove the fan motor speed leg lead from the time delay relay (TDR). This wire is attached to terminal-3 of TDR for single-phase and 3-phase

Table 6—Color Coding for 208/230–V Motor Leads

3-SPEED	2-SPEED
black = high speed	black = high speed
blue = medium speed	-
red = low speed	red = low speed

units. To change the speed, remove and replace with lead for desired blower motor speed. *Insulate the removed lead to avoid contact with chassis parts.*

FOR 460-V GE MOTORS

For color coding on the 460-v GE motor leads, see Table 7.

Table 7—Color Coding for 460-V GE Motor Leads

3-SPEED	2-SPEED
black = high	black = high
violet = jumper	blue = jumper
orange = medium	-
red = low	red = low

To change the speed of the indoor fan motor (IFM), remove fan motor speed lead from the time delay relay (TDR) and replace with the lead for the desired blower motor speed. The motor speed lead is attached to terminal-3 of TDR. For low and medium speeds black must be connected to the jumper wire. *Insulate removed lead end to avoid contact with chassis parts.* To select high speed on 460-v GE motors, separate the black female quick connect (QC) from the jumper lead male quick connect (QC) and connect the black lead to the BR. *Insulate the jumper to avoid contact with any chassis parts.*

#### COOLING SEQUENCE OF OPERATION

With the room thermostat SYSTEM switch in the COOL position and the FAN switch in the AUTO position, the cooling sequence of operation is as follows:

When the room temperature rises to a point that is slightly above the cooling control setting of the thermostat, the thermostat completes the circuit between thermostat terminal R to terminals Y and G. These completed circuits through the thermostat connect contactor coil (C) (through unit wire Y) and time delay relay (TDR) (through unit wire G) across the 24-v secondary of transformer (TRAN).

The normally open contacts of energized contactor (C) close and complete the circuit through compressor motor (COMP) to condenser (outdoor) fan motor (OFM). Both motors start instantly.

The set of normally open contacts of energized relay TDR close and complete the circuit through evaporator blower (indoor) fan motor (IFM).

**NOTE:** Once the compressor has started and then has stopped, it should not be started again until 5 minutes have elapsed.

The cooling cycle remains “on” until the room temperature drops to a point that is slightly below the cooling control setting of the room thermostat. At this point, the thermostat “breaks” the circuit between thermostat terminal R to terminals Y and G. These open circuits deenergize contactor coil C and relay coil TDR. The condenser and compressor motors stop. After a 30-second delay, the blower motor stops. The unit is in a “standby” condition, waiting for the next “call for cooling” from the room thermostat.

#### MAINTENANCE

To ensure continuing high performance, and to minimize the possibility of premature equipment failure, periodic maintenance must be performed on this equipment. This cooling unit should be

**Table 8—Wet Coil Air Delivery (Deduct 10 percent for 208v)\*  
Horizontal and Downflow Discharge  
Unit 50GS018-060**

		230 AND 460 VOLT											
Unit	Motor Speed	External Static Pressure (in. wg)											
		0.0	0.1	0.2	0.3	0.4	0.5	0.6	0.7	0.8	0.9	1.0	
018	Low	Watts	227	212	196	177	165	153	-	-	-	-	-
		Cfm	1000	915	825	710	530	340	-	-	-	-	-
	Med	Watts	-	-	-	-	-	-	-	-	-	-	-
		Cfm	-	-	-	-	-	-	-	-	-	-	-
	High	Watts	287	275	266	253	242	234	226	-	-	-	-
		Cfm	1150	1032	963	807	698	503	250	-	-	-	-
024	Low	Watts	280	275	270	267	264	262	260	-	-	-	-
		Cfm	880	825	765	693	600	450	281	-	-	-	-
	Med	Watts	380	375	365	360	355	350	344	335	312	-	-
		Cfm	1136	1085	1010	946	865	787	650	495	360	-	-
	High	Watts	485	475	470	460	455	445	437	430	415	385	-
		Cfm	1415	1332	1266	1180	1100	1000	900	780	480	256	-
030	Low	Watts	280	275	270	267	264	262	260	-	-	-	-
		Cfm	880	825	765	693	600	450	281	-	-	-	-
	Med	Watts	380	375	365	360	355	350	344	335	312	-	-
		Cfm	1136	1085	1010	946	865	787	650	495	360	-	-
	High	Watts	485	475	470	460	455	445	437	430	415	385	-
		Cfm	1415	1332	1266	1180	1100	1000	900	780	480	256	-
036	Low	Watts	-	470	458	445	430	415	399	384	-	-	-
		Cfm	-	1352	1257	1240	1199	1107	1015	924	-	-	-
	Med	Watts	-	-	514	501	487	471	455	438	422	-	-
		Cfm	-	-	1338	1295	1288	1181	1111	968	813	-	-
	High	Watts	-	-	-	646	636	626	614	602	589	-	-
		Cfm	-	-	-	1385	1268	1196	1159	1032	948	-	-
042	Low	Watts	-	675	660	650	640	630	620	610	595	580	-
		Cfm	-	1387	1326	1275	1204	1142	1081	995	918	850	-
	Med	Watts	-	886	855	825	795	778	765	750	735	718	700
		Cfm	-	1458	1406	1350	1285	1224	1163	1091	1013	932	870
	High	Watts	-	-	-	1000	950	925	910	890	875	855	833
		Cfm	-	-	-	1488	1424	1360	1296	1233	1148	1071	1005
048	Low	Watts	-	727	712	700	688	666	644	622	595	569	-
		Cfm	-	1640	1600	1575	1505	1450	1390	1300	1205	1145	-
	Med	Watts	-	853	836	821	807	782	756	730	699	667	640
		Cfm	-	1860	1830	1770	1700	1642	1565	1482	1385	1290	1210
	High	Watts	-	979	959	943	927	897	868	838	802	766	730
		Cfm	-	2090	2048	1997	1922	1845	1750	1600	1550	1425	1380
060	Low	Watts	1033	949	864	836	822	808	772	737	705	674	642
		Cfm	2050	2000	1945	1905	1880	1820	1775	1695	1627	1530	1480
	Med	Watts	1084	1054	1024	994	971	955	928	897	867	835	803
		Cfm	2248	2179	2110	2058	2000	1932	1885	1829	1740	1638	1569
	High	Watts	-	-	1184	1152	1120	1102	1084	1056	1029	997	965
		Cfm	-	-	2278	2207	2124	2041	2000	1960	1856	1748	1645

\* Air delivery values are based on operating voltage of 230v or 460v, wet coil, without filter or electric heater. Deduct filter and electric heater pressure drops to obtain static pressure available for ducting.

NOTES:

1. Do not operate the unit at a cooling airflow that is less than 350 cfm for each 12,000 Btu/h of rated cooling capacity. Evaporator coil frosting may occur at airflows below this point.
2. Dashes indicate portions of table that are beyond the blower motor capacity or are not recommended.

inspected at least once each year by a qualified service person. To troubleshoot heating or cooling of units, refer to tables at the back of the book.

The following are 50GS Cooling Charging Charts:

The following are 50GX Cooling Charging Charts:

NOTE TO EQUIPMENT OWNER: Consult your local dealer about the availability of a maintenance contract.

**Table 9—Wet Coil Air Delivery (Deduct 10 percent for 208v)\*  
Horizontal and Downflow Discharge  
Unit 50GX024-060**

		230 AND 460 VOLT											
Unit	Motor Speed	External Static Pressure (in. wg)											
		0.0	0.1	0.2	0.3	0.4	0.5	0.6	0.7	0.8	0.9	1.0	
024	Low	Watts	281	282	281	278	276	-	-	-	-	-	-
		Cfm	833	776	702	638	554						
	Med	Watts	-	-	-	375	370	363	357	352	-	-	-
		Cfm	-	-	-	894	800	754	636	518	-	-	-
	High	Watts	-	-	-	-	-	468	457	444	431	423	-
		Cfm	-	-	-	-	-	884	802	697	467	397	-
030	Low	Watts	246	244	243	241	-	-	-	-	-	-	-
		Cfm	910	806	749	680	-	-	-	-	-	-	-
	Med	Watts	343	339	336	332	328	322	317	-	-	-	-
		Cfm	1148	1104	1028	958	850	782	645	-	-	-	-
	High	Watts	-	-	-	-	441	432	421	410	400	-	-
		Cfm	-	-	-	-	1102	988	896	783	529	-	-
036	Low	Watts	-	470	458	445	430	415	399	384	-	-	-
		Cfm	-	1352	1257	1240	1199	1107	1015	924	-	-	-
	Med	Watts	-	-	514	501	487	471	455	438	422	-	-
		Cfm	-	-	1338	1295	1288	1181	1111	968	813	-	-
	High	Watts	-	-	-	646	636	626	614	602	589	-	-
		Cfm	-	-	-	1385	1268	1196	1159	1032	948	-	-
042	Low	Watts	-	625	614	605	593	574	549	518	485	454	-
		Cfm	-	1540	1510	1473	1396	1348	1288	1192	1124	1037	-
	Med	Watts	-	-	-	-	726	695	661	625	591	561	540
		Cfm	-	-	-	-	1648	1593	1530	1446	1352	1237	1114
	High	Watts	-	-	-	-	-	-	-	790	766	7421	713
		Cfm	-	-	-	-	-	-	-	1616	1492	1394	1283
048	Low	Watts	-	588	577	572	566	556	539	517	491	-	-
		Cfm	-	1514	1543	1467	1408	1374	1324	1237	1161	-	-
	Med	Watts	-	756	738	719	699	676	650	623	596	572	555
		Cfm	-	1785	1765	1706	1628	1577	1503	1421	1357	1298	1253
	High	Watts	-	-	-	-	896	862	829	800	775	752	728
		Cfm	-	-	-	-	1880	1804	1704	1547	1565	1406	1367
060	Low	Watts	903	898	873	842	814	792	777	764	743	701	618
		Cfm	2190	2158	2081	2026	1958	1866	1822	1744	1678	1535	1377
	Med	Watts	-	1002	978	960	941	914	880	839	798	764	750
		Cfm	-	2389	2291	2216	2120	2020	1952	1852	1727	1617	1549
	High	Watts	-	-	-	1080	1080	1066	1041	1008	972	938	-
		Cfm	-	-	-	2316	2181	2122	2101	2000	1802	1672	-

\* Air delivery values are based on operating voltage of 230v or 460v, wet coil, without filter or electric heater. Deduct filter and electric heater pressure drops to obtain static pressure available for ducting.

**NOTES:**

1. Do not operate the unit at a cooling airflow that is less than 350 cfm for each 12,000 Btu/h of rated cooling capacity. Evaporator coil frosting may occur at airflows below this point.
2. Dashes indicate portions of table that are beyond the blower motor capacity or are not recommended.

**⚠ WARNING**

The ability to properly perform maintenance on this equipment requires certain expertise, mechanical skills, tools, and equipment. If you do not possess these, do not attempt to perform any maintenance on this equipment other than those procedures recommended in the User's Manual. **FAILURE TO HEED THIS WARNING COULD RESULT IN SERIOUS PERSONAL INJURY AND POSSIBLE DAMAGE TO THIS EQUIPMENT.**

**⚠ WARNING**

Failure to follow these warnings could result in serious personal injury:

1. Turn off electrical power to the unit and install lockout tag before performing any maintenance or service on the unit.
2. Use extreme caution when removing panels and parts. As with any mechanical equipment, personal injury can result from sharp edges, etc.
3. Never place anything combustible either on, or in contact with, the unit.



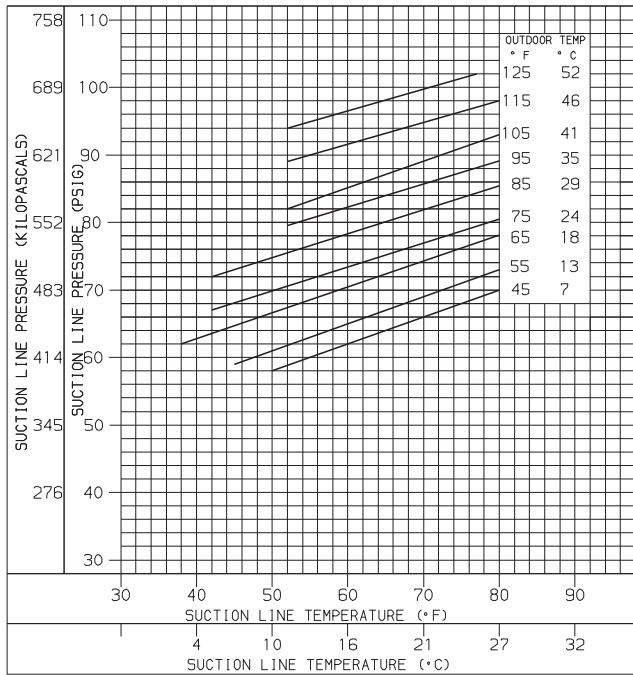

**Fig. 15—Cooling Charging Chart, 50GS018 Units**

C99037

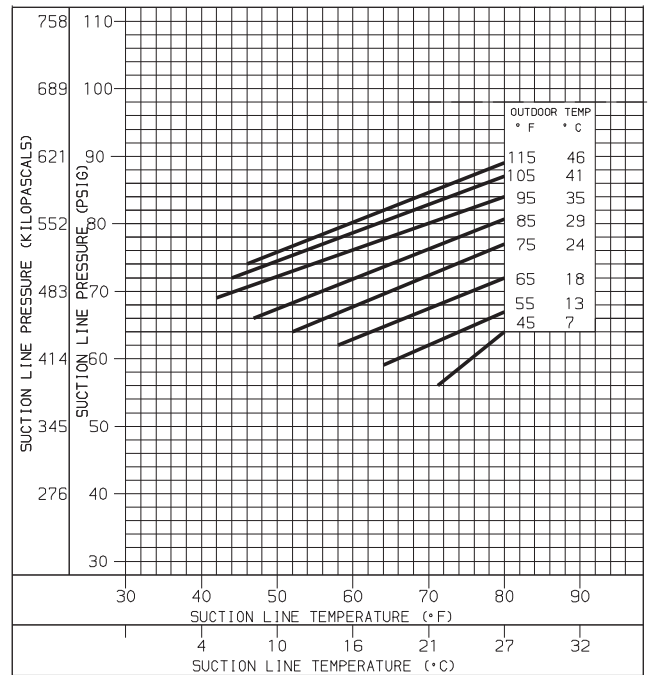

**Fig. 16—Cooling Charging Chart, 50GS024 Units**

C99039

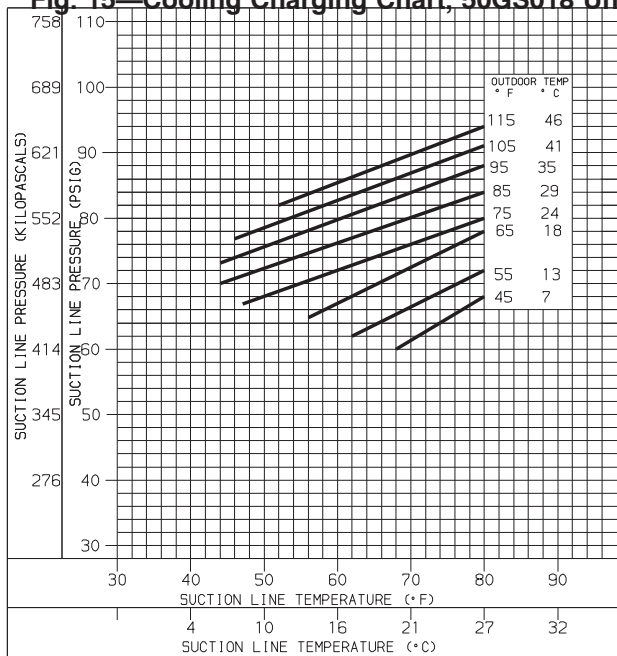

**Fig. 17—Cooling Charging Chart, 50GS030 Units**

C99038

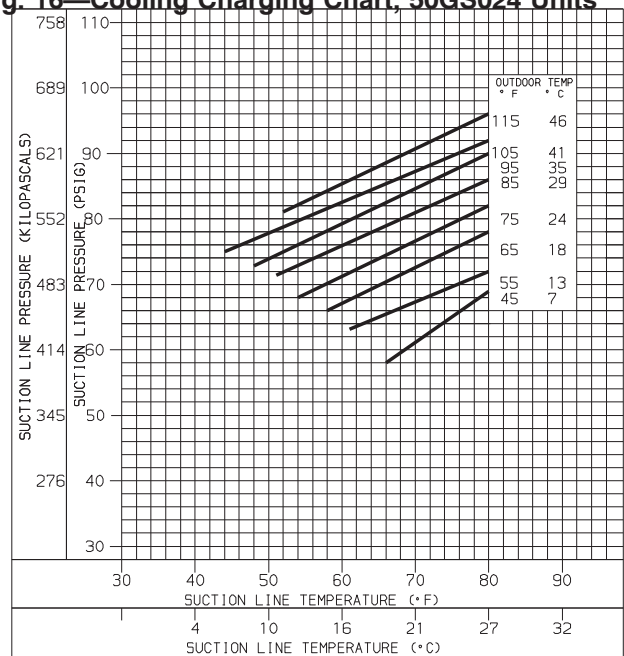

**Fig. 18—Cooling Charging Chart, 50GS036 Units**

C99040

**⚠ CAUTION**

Errors made when reconnecting wires may cause improper and dangerous operation. Label all wires prior to disconnection when servicing.

The minimum maintenance requirements for this equipment are as follows:

1. Inspect air filter(s) each month. Clean or replace when necessary.
2. Inspect indoor coil, drain pan, and condensate drain at least each cooling season for cleanliness. Clean when necessary.
3. Inspect blower motor and wheel for cleanliness and check lubrication each heating and cooling season. Clean when necessary.

4. Check electrical connections for tightness and controls for proper operation each heating and cooling season. Service when necessary.
5. Ensure electric wires are not in contact with refrigerant tubing or sharp metal edges.

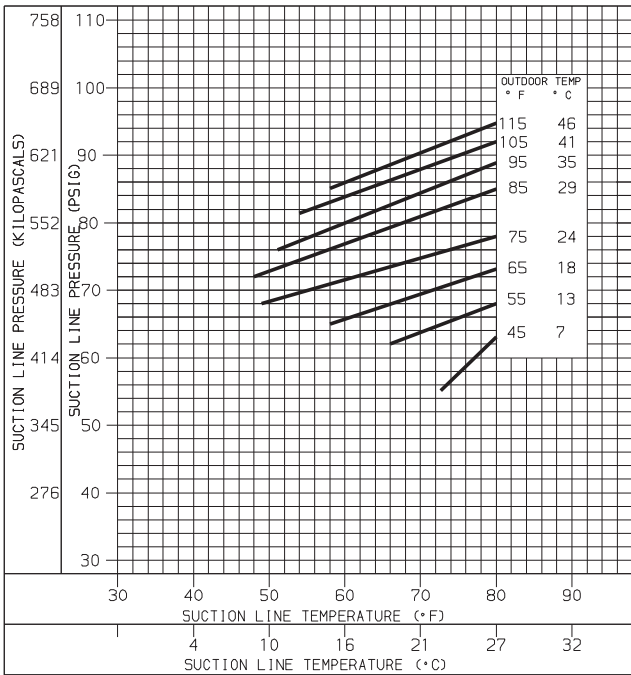

**Fig. 19—Cooling Charging Chart, 50GS042 Units**

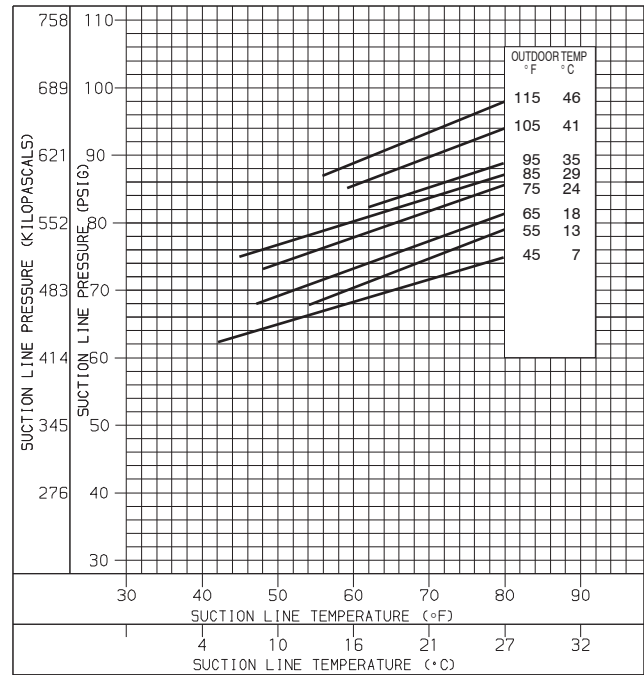

**Fig. 20—Cooling Charging Chart, 50GS048 Units**

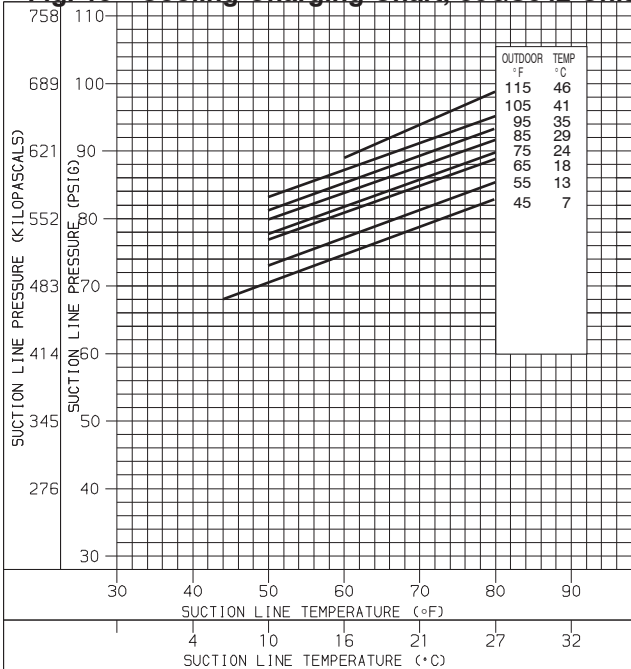

**Fig. 21—Cooling Charging Chart, 50GS060 Units**

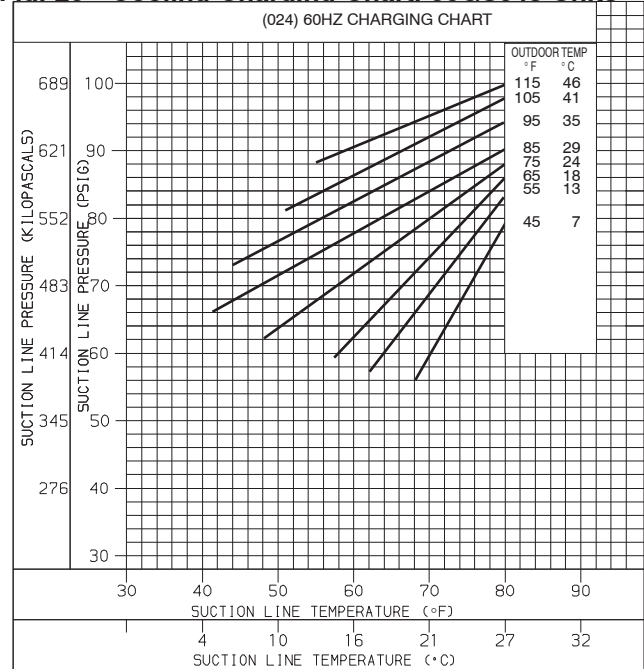

**Fig. 22—Cooling Charging Chart, 50GX024 Units**

**AIR FILTER**

**⚠ CAUTION**

Never operate the unit without a suitable air filter in the return-air duct system. Always replace the filter with the same dimensional size and type as originally installed. See Tables 1 and 2 for recommended filter sizes.

Inspect air filter(s) at least once each month and replace (throwaway-type) or clean (cleanable-type) at least twice during each heating and cooling season or whenever the filter(s) becomes clogged with dust and lint.

**EVAPORATOR BLOWER AND MOTOR**

**NOTE:** All motors are prelubricated. Do not attempt to lubricate these motors.

For longer life, operating economy, and continuing efficiency, clean accumulated dirt and grease from the blower wheel and motor annually.

**⚠ WARNING**

Disconnect and tag electrical power to the unit before cleaning the blower motor and wheel. Failure to adhere to this warning could cause personal injury or death.

To clean the blower motor and wheel:

1. Remove and disassemble blower assembly as follows:
  - a. Remove unit access panel.
  - b. Disconnect motor lead from time delay relay (TDR). Disconnect yellow lead from terminal L2 of the contactor.

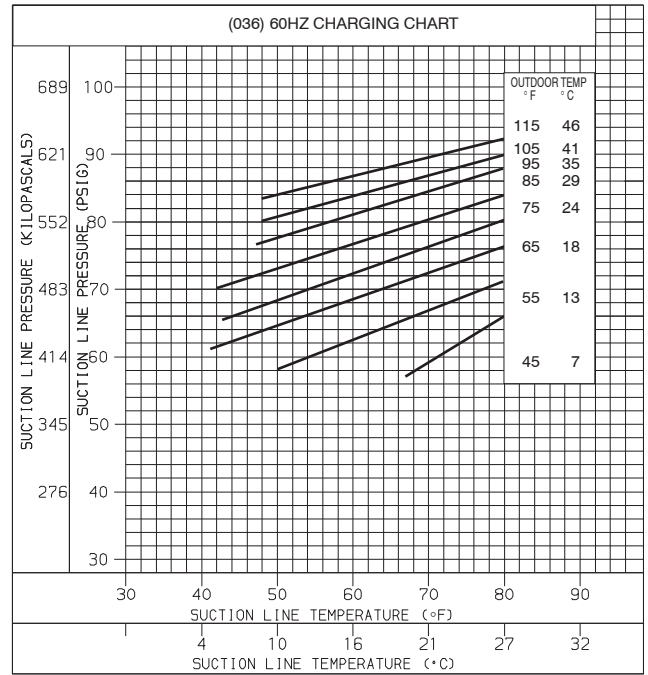
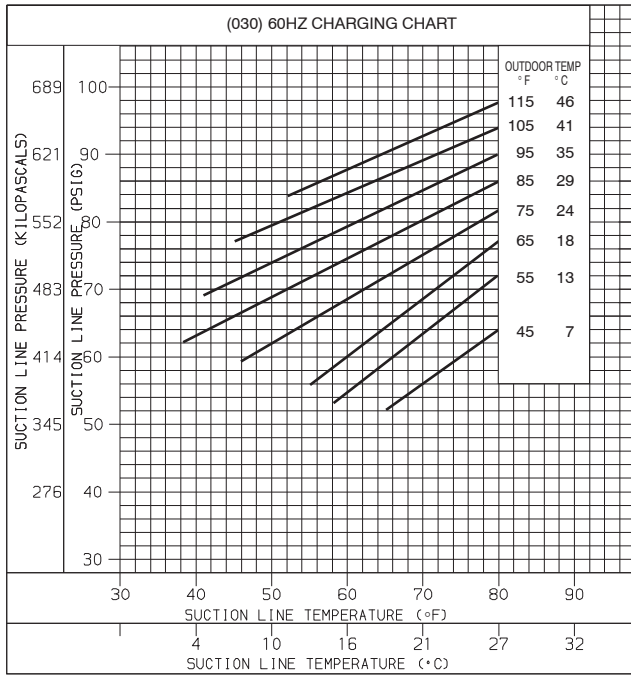

**Fig. 23—Cooling Charging Chart, 50GX030 Units**

**Fig. 24—Cooling Charging Chart, 50GX036 Units**

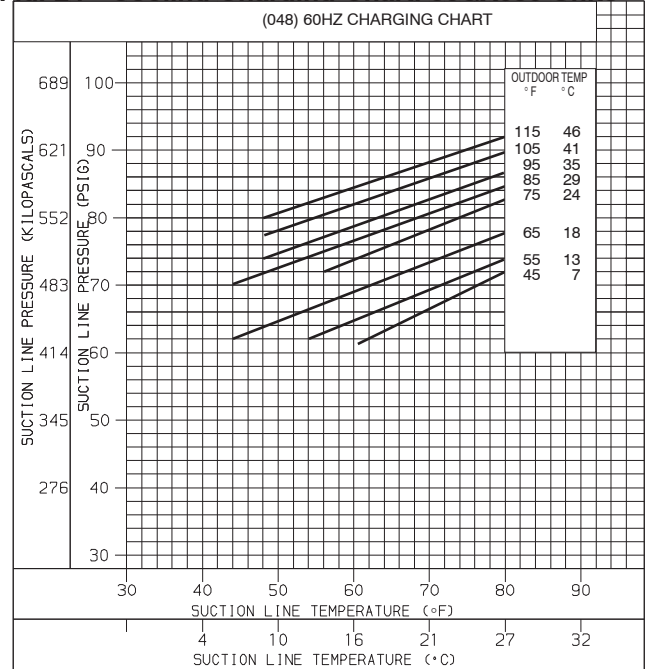
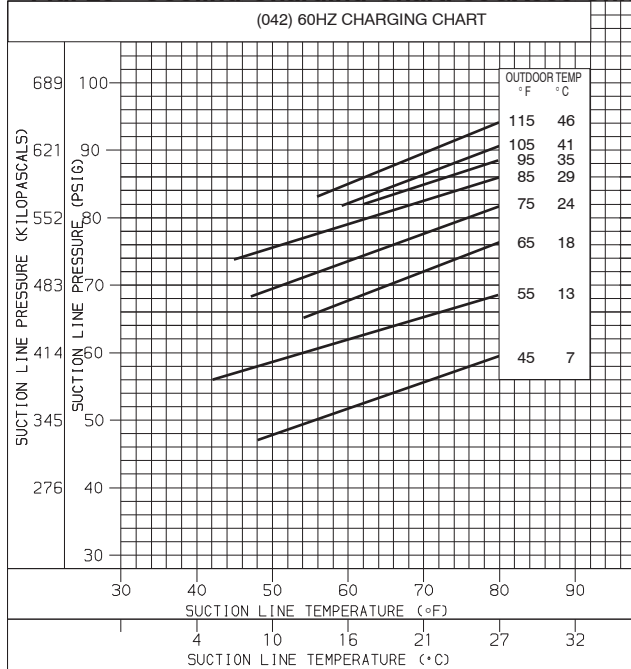
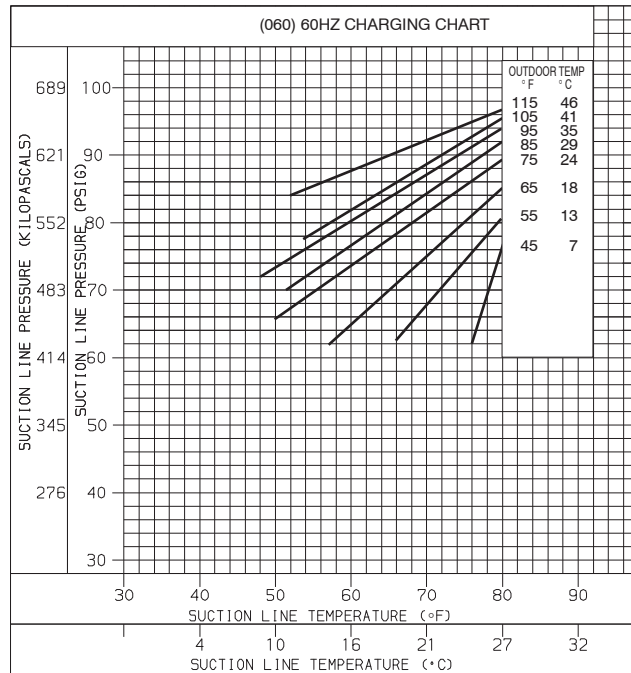

**Fig. 25—Cooling Charging Chart, 50GX042 Units**

**Fig. 26—Cooling Charging Chart, 50GX048 Units**

- c. On all units remove blower assembly from unit. Remove screws securing blower to blower partition and slide assembly out. Be careful not to tear insulation in blower compartment.
  - d. Ensure proper reassembly by marking blower wheel and motor in relation to blower housing before disassembly.
  - e. Loosen setscrew(s) that secures wheel to motor shaft, remove screws that secure motor mount brackets to housing, and slide motor and motor mount out of housing.
2. Remove and clean blower wheel as follows:
- a. Ensure proper reassembly by marking wheel orientation.
  - b. Lift wheel from housing. When handling and/or cleaning blower wheel, be sure not to disturb balance weights (clips) on blower wheel vanes.

- c. Remove caked-on dirt from wheel and housing with a brush. Remove lint and/or dirt accumulations from wheel and housing with vacuum cleaner, using soft brush attachment. Remove grease and oil with mild solvent.
  - d. Reassemble wheel into housing.
  - e. Reassemble motor into housing. Be sure setscrews are tightened on motor shaft flats and not on round part of shaft.
  - f. Reinstall unit access panel.
3. Restore electrical power to unit. Start unit and check for proper blower rotation and motor speeds during heating and cooling cycles.



C99049

**Fig. 27—Cooling Charging Chart, 50GX060 Units**

**CONDENSER COIL, EVAPORATOR COIL, AND CONDENSATE DRAIN PAN**

Inspect the condenser coil, evaporator coil, and condensate drain pan at least once each year.

The coils are easily cleaned when dry; therefore, inspect and clean the coils either before or after each cooling season. Remove all obstructions, including weeds and shrubs, that interfere with the airflow through the condenser coil.

Straighten bent fins with a fin comb. If coated with dirt or lint, clean the coils with a vacuum cleaner, using the soft brush attachment. Be careful not to bend the fins. If coated with oil or grease, clean the coils with a mild detergent-and-water solution. Rinse coils with clear water, using a garden hose. Be careful not to splash water on motors, insulation, wiring, or air filter(s). For best results, spray condenser coil fins from inside to outside the unit. On units with an outer and inner condenser coil, be sure to clean between the coils. Be sure to flush all dirt and debris from the unit base.

Inspect the drain pan and condensate drain line when inspecting the coils. Clean the drain pan and condensate drain by removing all foreign matter from the pan. Flush the pan and drain tube with clear water. Do not splash water on the insulation, motor, wiring, or air filter(s). If the drain tube is restricted, clear it with a “plumbers snake” or similar probe device. Ensure that the auxiliary drain port above the drain tube is also clear

**CONDENSER FAN**

**⚠ CAUTION**

Keep the condenser fan free from all obstructions to ensure proper cooling operation. Never place articles on top of the unit. Damage to unit may result.

1. Remove 6 screws holding condenser grille and motor to top cover.
2. Turn motor/grille assembly upside down on top cover to expose the fan blade.
3. Inspect the fan blades for cracks or bends.

4. If fan needs to be removed, loosen the setscrew and slide the fan off the motor shaft.
5. When replacing fan blade, position blade so that the hub is 1/8 in. away from the motor end (1/8 in. of motor shaft will be visible).
6. Ensure that setscrew engages the flat area on the motor shaft when tightening
7. Replace grille.

**ELECTRICAL CONTROLS AND WIRING**

Inspect and check the electrical controls and wiring annually. *Be sure to turn off the electrical power to the unit and install lockout tag.*

Remove access panel to locate all the electrical controls and wiring. Check all electrical connections for tightness. Tighten all screw connections. If any smoky or burned connections are noticed, disassemble the connection, clean all the parts, restrip the wire end and reassemble the connection properly and securely.

After inspecting the electrical controls and wiring, replace the access panel. Start the unit, and observe at least one complete heating cycle and one complete cooling cycle to ensure proper operation. If discrepancies are observed in either or both operating cycles, or if a suspected malfunction has occurred, check each electrical component with the proper electrical instrumentation. Refer to the unit wiring label when making these checkouts.

**NOTE:** Refer to the heating and/or cooling sequence of operation in this publication as an aid in determining proper control operation

**REFRIGERANT CIRCUIT**

Inspect all refrigerant tubing connections and the unit base for oil accumulations annually. Detecting oil generally indicates a refrigerant leak.

**⚠ WARNING**

System under pressure. Relieve pressure and recover all refrigerant before system repair or final unit disposal to avoid personal injury or death. Use all service ports and open all flow-control devices, including solenoid valves.

If oil is detected or if low cooling performance is suspected, leak-test all refrigerant tubing using an electronic leak-detector, halide torch, or liquid-soap solution. If a refrigerant leak is detected, refer to Check for Refrigerant Leaks section.

If no refrigerant leaks are found and low cooling performance is suspected, refer to Checking and Adjusting Refrigerant Charge section.

**EVAPORATOR AIRFLOW**

The heating and/or cooling air-flow does not require checking unless improper performance is suspected. *If a problem exists, be sure that all supply- and return-air grilles are open and free from*

*obstructions, and that the air filter is clean.* When necessary, refer to Indoor Airflow and Airflow Adjustments section to check the system airflow.

**METERING DEVICE — ACUTROL DEVICE**

This metering device is a fixed orifice and is located in the header to the evaporator coil.

**LIQUID LINE STRAINER**

The liquid line strainer (to protect metering device) is made of wire mesh and located in the liquid line on the inlet side of the metering device.

**TROUBLESHOOTING**

Use the *Troubleshooting–Cooling* guide (see Table 10) if problems occur with these units.

**START-UP CHECKLIST**

Use the Start-Up checklist to ensure proper start-up procedures are followed.

**Table 10—Troubleshooting—Cooling**

<b>SYMPTOM</b>	<b>CAUSE</b>	<b>REMEDY</b>
<b>Compressor and condenser fan will not start.</b>	Power Failure	Call power company
	Fuse blown or circuit breaker tripped	Replace fuse or reset circuit breaker
	Defective thermostat, contractor, transformer, or control relay	Replace component
	Insufficient line voltage	Determine cause and correct
	Incorrect or faulty wiring	Check wiring diagram and rewire correctly
	Thermostat setting too high	Lower thermostat setting below room temperature
<b>Compressor will not start but condenser fan runs.</b>	Faulty wiring or loose connections in compressor circuit	Check wiring and repair or replace
	Compressor motor burned out, seized, or internal overload open	Determine cause Replace compressor
	Defective run/start capacitor, overload, start relay	Determine cause and replace
	One leg of 3-phase power dead	Replace fuse or reset circuit breaker Determine cause
<b>Three-phase scroll compressor (50GS048, 50GX030-060) makes excessive noise, and there may be a low pressure differential.</b>	Scroll compressor is rotating in the wrong direction	Correct the direction of rotation by reversing the 3-phase power leads to the unit. Shut down unit to allow pressures to equalize.
<b>Compressor cycles (other than normally satisfying thermostat).</b>	Refrigerant overcharge or undercharge	Recover refrigerant, evacuate system, and re-charge to capacities shown on nameplate
	Defective compressor	Replace and determine cause
	Insufficient line voltage	Determine cause and correct
	Blocked condenser	Determine cause and correct
	Defective run/start capacitor, overload or start relay	Determine cause and replace
	Defective thermostat	Replace thermostat
	Faulty condenser-fan motor or capacitor	Replace
	Restriction in refrigerant system	Locate restriction and remove
<b>Compressor operates continuously.</b>	Dirty air filter	Replace filter
	Unit undersized for load	Decrease load or increase unit size
	Thermostat set too low	Reset thermostat
	Low refrigerant charge	Locate leak, repair, and recharge
	Leaking valves in compressor	Replace compressor
	Air in system	Recover refrigerant, evacuate system, and re-charge
	Condenser coil dirty or restricted	Clean coil or remove restriction
	Restriction in refrigerant system	Locate restriction and remove
<b>Excessive head pressure.</b>	Dirty air filter	Replace filter
	Dirty condenser coil	Clean coil
	Refrigerant overcharged	Recover excess refrigerant
	Air in system	Recover refrigerant, evacuate system, and re-charge
	Condenser air restricted or air short-cycling	Determine cause and correct
<b>Head pressure too low.</b>	Low refrigerant charge	Check for leaks, repair and recharge
	Compressor valves leaking	Replace compressor
	Restriction in liquid tube	Remove restriction
<b>Excessive suction pressure.</b>	High heat load	Check for source and eliminate
	Compressor valves leaking	Replace compressor
	Refrigerant overcharged	Recover excess refrigerant
<b>Suction pressure too low.</b>	Dirty air filter	Replace Filter
	Low refrigerant charge	Check for leaks, repair, and recharge
	Metering device or low side restricted	Remove source of restriction
	Insufficient evaporator airflow	Increase air quantity Check filter- replace if necessary
	Temperature too low in conditioned area	Reset thermostat
	Outdoor ambient below 40°F	Install low-ambient kit
Field-installed filter-drier restricted	Replace	



**START-UP CHECKLIST  
(REMOVE AND STORE IN JOB FILE)**

**I. PRELIMINARY INFORMATION**

Model No .....  
Serial No .....  
Date .....  
Technician .....  
Job/ Location.....

**II. PRE-START-UP**

- \_\_\_ Verify that all packing materials have been removed from unit
- \_\_\_ Verify that condensate connection is installed per installation instructions
- \_\_\_ Check all electrical connections and terminals for tightness
- \_\_\_ Check that indoor (evaporator) air filter is clean and in place
- \_\_\_ Verify that unit installation is level
- \_\_\_ Check fan wheel propeller for location in housing and setscrew tightness

**III. START-UP**

Supply Voltage: L1-L2(C-S) \_\_\_\_\_ L2-L3(S-R) \_\_\_\_\_ L3-L1(R-C) \_\_\_\_\_  
Compressor Amps: L1(C) \_\_\_\_\_ L2(S) \_\_\_\_\_ L3(R) \_\_\_\_\_  
Indoor (Evaporator) Fan Amps: \_\_\_\_\_

**TEMPERATURE**

Outdoor (Condenser) Air Temperature: \_\_\_\_\_ DB  
Return-Air Temperature: \_\_\_\_\_ DB \_\_\_\_\_ WB  
Cooling Supply Air: \_\_\_\_\_ DB \_\_\_\_\_ WB

**PRESSURES**

Refrigerant Suction \_\_\_\_\_ psig  
Suction Line Temp\* \_\_\_\_\_  
Refrigerant Discharge \_\_\_\_\_ psig  
Discharge Temp† \_\_\_\_\_  
\_\_\_ Verify Refrigerant charge using charging tables  
\_\_\_ Verify that 3-phase scroll compressor (50GS048 and 50GX030-060) is rotating in correct direction.

\* Measured at suction inlet to compressor

† Measured at liquid line leaving condenser

**Manufacturer reserves the right to discontinue, or change at any time, specifications or designs without notice and without incurring obligations.**